

# Data Compression

DEBRA A. LELEWER and DANIEL S. HIRSCHBERG

*Department of Information and Computer Science, University of California, Irvine, California 92717*

This paper surveys a variety of data compression methods spanning almost 40 years of research, from the work of Shannon, Fano, and Huffman in the late 1940s to a technique developed in 1986. The aim of data compression is to reduce redundancy in stored or communicated data, thus increasing effective data density. Data compression has important application in the areas of file storage and distributed systems. Concepts from information theory as they relate to the goals and evaluation of data compression methods are discussed briefly. A framework for evaluation and comparison of methods is constructed and applied to the algorithms presented. Comparisons of both theoretical and empirical natures are reported, and possibilities for future research are suggested.

Categories and Subject Descriptors: E.4 [Data]: Coding and Information Theory—*data compaction and compression*

General Terms: Algorithms, Theory

Additional Key Words and Phrases: Adaptive coding, adaptive Huffman codes, coding, coding theory, file compression, Huffman codes, minimum-redundancy codes, optimal codes, prefix codes, text compression

## INTRODUCTION

Data compression is often referred to as coding, where coding is a general term encompassing any special representation of data that satisfies a given need. Information theory is defined as the study of efficient coding and its consequences in the form of speed of transmission and probability of error [Ingels 1971]. Data compression may be viewed as a branch of information theory in which the primary objective is to minimize the amount of data to be transmitted. The purpose of this paper is to present and analyze a variety of data compression algorithms.

A simple characterization of data compression is that it involves transforming a string of characters in some representation (such as ASCII) into a new string (e.g., of bits) that contains the same infor-

mation but whose length is as small as possible. Data compression has important application in the areas of data transmission and data storage. Many data processing applications require storage of large volumes of data, and the number of such applications is constantly increasing as the use of computers extends to new disciplines. At the same time, the proliferation of computer communication networks is resulting in massive transfer of data over communication links. Compressing data to be stored or transmitted reduces storage and/or communication costs. When the amount of data to be transmitted is reduced, the effect is that of increasing the capacity of the communication channel. Similarly, compressing a file to half of its original size is equivalent to doubling the capacity of the storage medium. It may then become feasible to store the data at a

---

Permission to copy without fee all or part of this material is granted provided that the copies are not made or distributed for direct commercial advantage, the ACM copyright notice and the title of the publication and its date appear, and notice is given that copying is by permission of the Association for Computing Machinery. To copy otherwise, or to republish, requires a fee and/or specific permission.

© 1988 ACM 0360-0300/87/0900-0261 \$1.50

## CONTENTS

## INTRODUCTION

## 1. FUNDAMENTAL CONCEPTS

- 1.1 Definitions
- 1.2 Classification of Methods
- 1.3 A Data Compression Model
- 1.4 Motivation

## 2. SEMANTIC DEPENDENT METHODS

## 3. STATIC DEFINED-WORD SCHEMES

- 3.1 Shannon-Fano Code
- 3.2 Static Huffman Coding
- 3.3 Universal Codes and Representations of the Integers
- 3.4 Arithmetic Coding

## 4. ADAPTIVE HUFFMAN CODING

- 4.1 Algorithm FGK
- 4.2 Algorithm V

## 5. OTHER ADAPTIVE METHODS

- 5.1 Lempel-Ziv Codes
- 5.2 Algorithm BSTW

## 6. EMPIRICAL RESULTS

## 7. SUSCEPTIBILITY TO ERROR

- 7.1 Static Codes
- 7.2 Adaptive Codes

## 8. NEW DIRECTIONS

## 9. SUMMARY

## REFERENCES

higher, thus faster, level of the storage hierarchy and reduce the load on the input/output channels of the computer system.

Many of the methods discussed in this paper are implemented in production systems. The UNIX<sup>1</sup> utilities *compact* and *compress* are based on methods discussed in Sections 4 and 5, respectively [UNIX 1984]. Popular file archival systems such as *ARC* and *PKARC* use techniques presented in Sections 3 and 5 [ARC 1986; PKARC 1987]. The savings achieved by data compression can be dramatic; reduction as high as 80% is not uncommon [Reghbati 1981]. Typical values of compression provided by *compact* are text (38%), Pascal source (43%), C source (36%), and binary (19%). *Compress* generally achieves better compression (50–60% for text such as source code and English) and takes less time to compute [UNIX 1984]. Arithmetic coding (Section 3.4) has

been reported to reduce a file to anywhere from 12.1 to 73.5% of its original size [Witten et al. 1987]. Cormack reports that data compression programs based on Huffman coding (Section 3.2) reduced the size of a large student-record database by 42.1% when only some of the information was compressed. As a consequence of this size reduction, the number of disk operations required to load the database was reduced by 32.7% [Cormack 1985]. Data compression routines developed with specific applications in mind have achieved compression factors as high as 98% [Severance 1983].

Although coding for purposes of data security (cryptography) and codes that guarantee a certain level of data integrity (error detection/correction) are topics worthy of attention, they do not fall under the umbrella of data compression. With the exception of a brief discussion of the susceptibility to error of the methods surveyed (Section 7), a discrete noiseless channel is assumed. That is, we assume a system in which a sequence of symbols chosen from a finite alphabet can be transmitted from one point to another without the possibility of error. Of course, the coding schemes described here may be combined with data security or error-correcting codes.

Much of the available literature on data compression approaches the topic from the point of view of data transmission. As noted earlier, data compression is of value in data storage as well. Although this discussion is framed in the terminology of data transmission, compression and decompression of data files are essentially the same tasks as sending and receiving data over a communication channel. The focus of this paper is on algorithms for data compression; it does not deal with hardware aspects of data transmission. The reader is referred to Cappellini [1985] for a discussion of techniques with natural hardware implementation.

Background concepts in the form of terminology and a model for the study of data compression are provided in Section 1. Applications of data compression are also discussed in Section 1 to provide motivation for the material that follows.

<sup>1</sup> UNIX is a trademark of AT&T Bell Laboratories.

Although the primary focus of this survey is data compression methods of general utility, Section 2 includes examples from the literature in which ingenuity applied to domain-specific problems has yielded interesting coding techniques. These techniques are referred to as *semantic dependent* since they are designed to exploit the context and semantics of the data to achieve redundancy reduction. Semantic-dependent techniques include the use of quadrees, run-length encoding, or difference mapping for storage and transmission of image data [Gonzalez and Wintz 1977; Samet 1984].

General-purpose techniques, which assume no knowledge of the information content of the data, are described in Sections 3–5. These descriptions are sufficiently detailed to provide an understanding of the techniques. The reader will need to consult the references for implementation details. In most cases only worst-case analyses of the methods are feasible. To provide a more realistic picture of their effectiveness, empirical data are presented in Section 6. The susceptibility to error of the algorithms surveyed is discussed in Section 7, and possible directions for future research are considered in Section 8.

## 1. FUNDAMENTAL CONCEPTS

A brief introduction to information theory is provided in this section. The definitions and assumptions necessary to a comprehensive discussion and evaluation of data compression methods are discussed. The following string of characters is used to illustrate the concepts defined: *EXAMPLE* = “*aa bbb cccc dddd eeeee fffffffggggggg*”.

### 1.1 Definitions

A *code* is a mapping of *source messages* (words from the source alphabet  $\alpha$ ) into *codewords* (words of the code alphabet  $\beta$ ). The source messages are the basic units into which the string to be represented is partitioned. These basic units may be single symbols from the source alphabet, or they may be strings of symbols. For string *EXAMPLE*,  $\alpha = \{a, b, c, d, e, f, g, \text{space}\}$ . For purposes of explanation,  $\beta$  is taken to

Source message	Codeword
<i>a</i>	000
<i>b</i>	001
<i>c</i>	010
<i>d</i>	011
<i>e</i>	100
<i>f</i>	101
<i>g</i>	110
<i>space</i>	111

Figure 1. A block–block code for *EXAMPLE*.

Source message	Codeword
<i>aa</i>	0
<i>bbb</i>	1
<i>cccc</i>	10
<i>dddd</i>	11
<i>eeeeee</i>	100
<i>ffffff</i>	101
<i>ggggggg</i>	110
<i>space</i>	111

Figure 2. A variable–variable code for *EXAMPLE*.

be  $\{0, 1\}$ . Codes can be categorized as block–block, block–variable, variable–block, or variable–variable, where block–block indicates that the source messages and codewords are of fixed length and variable–variable codes map variable-length source messages into variable-length codewords. A block–block code for *EXAMPLE* is shown in Figure 1, and a variable–variable code is given in Figure 2. If the string *EXAMPLE* were coded using the Figure 1 code, the length of the coded message would be 120; using Figure 2 the length would be 30.

The oldest and most widely used codes, ASCII and EBCDIC, are examples of block–block codes, mapping an alphabet of 64 (or 256) single characters onto 6-bit (or 8-bit) codewords. These are not discussed, since they do not provide compression. The codes featured in this survey are of the block–variable, variable–variable, and variable–block types.

When source messages of variable length are allowed, the question of how a message *ensemble* (sequence of messages) is parsed into individual messages arises. Many of the algorithms described here are *defined-word schemes*. That is, the set of source messages is determined before the

invocation of the coding scheme. For example, in text file processing, each character may constitute a message, or messages may be defined to consist of alphanumeric and nonalphanumeric strings. In Pascal source code, each token may represent a message. All codes involving fixed-length source messages are, by default, defined-word codes. In *free-parse* methods, the coding algorithm itself parses the ensemble into variable-length sequences of symbols. Most of the known data compression methods are defined-word schemes; the free-parse model differs in a fundamental way from the classical coding paradigm.

A code is *distinct* if each codeword is distinguishable from every other (i.e., the mapping from source messages to codewords is one to one). A distinct code is *uniquely decodable* if every codeword is identifiable when immersed in a sequence of codewords. Clearly, each of these features is desirable. The codes of Figures 1 and 2 are both distinct, but the code of Figure 2 is not uniquely decodable. For example, the coded message 11 could be decoded as either "ddddd" or "bbbbbb". A uniquely decodable code is a *prefix code* (or *prefix-free code*) if it has the prefix property, which requires that no codeword be a proper prefix of any other codeword. All uniquely decodable block-block and variable-block codes are prefix codes. The code with codewords {1, 100000, 00} is an example of a code that is uniquely decodable but that does not have the prefix property. Prefix codes are *instantaneously decodable*; that is, they have the desirable property that the coded message can be parsed into codewords without the need for lookahead. In order to decode a message encoded using the codeword set {1, 100000, 00}, lookahead is required. For example, the first codeword of the message 1000000001 is 1, but this cannot be determined until the last (tenth) symbol of the message is read (if the string of zeros had been of odd length, the first codeword would have been 100000).

A *minimal* prefix code is a prefix code such that, if  $x$  is a proper prefix of some codeword, then  $x\sigma$  is either a codeword or a proper prefix of a codeword for each letter

$\sigma$  in  $\beta$ . The set of codewords {00, 01, 10} is an example of a prefix code that is not minimal. The fact that 1 is a proper prefix of the codeword 10 requires that 11 be either a codeword or a proper prefix of a codeword, and it is neither. Intuitively, the minimality constraint prevents the use of codewords that are longer than necessary. In the above example the codeword 10 could be replaced by the codeword 1, yielding a minimal prefix code with shorter codewords. The codes discussed in this paper are all minimal prefix codes.

In this section a *code* has been defined to be a mapping from a source alphabet to a code alphabet; we now define related terms. The process of transforming a source ensemble into a coded message is *coding* or *encoding*. The encoded message may be referred to as an encoding of the source ensemble. The algorithm that constructs the mapping and uses it to transform the source ensemble is called the *encoder*. The *decoder* performs the inverse operation, restoring the coded message to its original form.

## 1.2 Classification of Methods

Not only are data compression schemes categorized with respect to message and codeword lengths, but they are also classified as either static or dynamic. A *static* method is one in which the mapping from the set of messages to the set of codewords is fixed before transmission begins, so that a given message is represented by the same codeword every time it appears in the message ensemble. The classic static defined-word scheme is Huffman coding [Huffman 1952]. In Huffman coding, the assignment of codewords to source messages is based on the probabilities with which the source messages appear in the message ensemble. Messages that appear frequently are represented by short codewords; messages with smaller probabilities map to longer codewords. These probabilities are determined before transmission begins. A Huffman code for the ensemble *EXAMPLE* is given in Figure 3. If *EXAMPLE* were coded using this Huffman mapping, the length of the coded message would be 117. Static Huffman coding is discussed in Section 3.2;

Source message	Probability	Codeword
<i>a</i>	2/40	1001
<i>b</i>	3/40	1000
<i>c</i>	4/40	011
<i>d</i>	5/40	010
<i>e</i>	6/40	111
<i>f</i>	7/40	110
<i>g</i>	8/40	00
<i>space</i>	5/40	101

**Figure 3.** A Huffman code for the message *EXAMPLE* (code length = 117).

Source message	Probability	Codeword
<i>a</i>	2/6	10
<i>b</i>	3/6	0
<i>space</i>	1/6	11

**Figure 4.** A dynamic Huffman code table for the prefix "*aa bbb*" of message *EXAMPLE*.

other static schemes are discussed in Sections 2 and 3.

A code is *dynamic* if the mapping from the set of messages to the set of codewords changes over time. For example, dynamic Huffman coding involves computing an approximation to the probabilities of occurrence "on the fly," as the ensemble is being transmitted. The assignment of codewords to messages is based on the values of the relative frequencies of occurrence at each point in time. A message *x* may be represented by a short codeword early in the transmission because it occurs frequently at the beginning of the ensemble, even though its probability of occurrence over the total ensemble is low. Later, when the more probable messages begin to occur with higher frequency, the short codeword will be mapped to one of the higher probability messages, and *x* will be mapped to a longer codeword. As an illustration, Figure 4 presents a dynamic Huffman code table corresponding to the prefix "*aa bbb*" of *EXAMPLE*. Although the frequency of *space* over the entire message is greater than that of *b*, at this point *b* has higher frequency and therefore is mapped to the shorter codeword.

Dynamic codes are also referred to in the literature as *adaptive*, in that they adapt to changes in ensemble characteristics over time. The term *adaptive* is used for the remainder of this paper; the fact that these codes adapt to changing characteristics is the source of their appeal. Some adaptive methods adapt to changing patterns in the source [Welch 1984], whereas others exploit *locality of reference* [Bentley et al. 1986]. *Locality of reference* is the tendency,

common in a wide variety of text types, for a particular word to occur frequently for short periods of time and then fall into disuse for long periods.

All of the adaptive methods are *one-pass* methods; only one scan of the ensemble is required. Static Huffman coding requires two passes: one pass to compute probabilities and determine the mapping, and a second pass for transmission. Thus, as long as the encoding and decoding times of an adaptive method are not substantially greater than those of a static method, the fact that an initial scan is not needed implies a speed improvement in the adaptive case. In addition, the mapping determined in the first pass of a static coding scheme must be transmitted by the encoder to the decoder. The mapping may preface each transmission (i.e., each file sent), or a single mapping may be agreed upon and used for multiple transmissions. In one-pass methods the encoder defines and redefines the mapping dynamically during transmission. The decoder must define and redefine the mapping in sympathy, in essence "learning" the mapping as codewords are received. Adaptive methods are discussed in Sections 4 and 5.

An algorithm may also be a *hybrid*, neither completely static nor completely dynamic. In a simple hybrid scheme, sender and receiver maintain identical *codebooks* containing *k* static codes. For each transmission, the sender must choose one of the *k* previously agreed upon codes and inform the receiver of the choice (by transmitting first the "name" or number of the chosen code). Hybrid methods are discussed further in Sections 2 and 3.2.

### 1.3 A Data Compression Model

In order to discuss the relative merits of data compression techniques, a framework

for comparison must be established. There are two dimensions along which each of the schemes discussed here may be measured: algorithm complexity and amount of compression. When data compression is used in a data transmission application, the goal is speed. Speed of transmission depends on the number of bits sent, the time required for the encoder to generate the coded message, and the time required for the decoder to recover the original ensemble. In a data storage application, although the degree of compression is the primary concern, it is nonetheless necessary that the algorithm be efficient in order for the scheme to be practical. For a static scheme, there are three algorithms to analyze: the map construction algorithm, the encoding algorithm, and the decoding algorithm. For a dynamic scheme, there are just two algorithms: the encoding algorithm and the decoding algorithm.

Several common measures of compression have been suggested: redundancy [Shannon and Weaver 1949], average message length [Huffman 1952], and compression ratio [Rubin 1976; Ruth and Kreutzer 1972]. These measures are defined below. Related to each of these measures are assumptions about the characteristics of the source. It is generally assumed in information theory that all statistical parameters of a message source are known with perfect accuracy [Gilbert 1971]. The most common model is that of a discrete memoryless source; a source whose output is a sequence of letters (or messages), each letter being a selection from some fixed alphabet  $a_1, \dots, a_n$ . The letters are taken to be random, statistically independent selections from the alphabet, the selection being made according to some fixed probability assignment  $p(a_1), \dots, p(a_n)$  [Gallager 1968]. Without loss of generality, the code alphabet is assumed to be  $\{0, 1\}$  throughout this paper. The modifications necessary for larger code alphabets are straightforward.

We assume that any cost associated with the code letters is uniform. This is a reasonable assumption, although it omits applications like telegraphy where the

code symbols are of different durations. The assumption is also important, since the problem of constructing optimal codes over unequal code letter costs is a significantly different and more difficult problem. Perl et al. [1975] and Varn [1971] have developed algorithms for minimum-redundancy prefix coding in the case of arbitrary symbol cost and equal codeword probability. The assumption of equal probabilities mitigates the difficulty presented by the variable symbol cost. For the more general unequal letter costs and unequal probabilities model, Karp [1961] has proposed an integer linear programming approach. There have been several approximation algorithms proposed for this more difficult problem [Krause 1962; Cot 1977; Mehlhorn 1980].

When data are compressed, the goal is to reduce redundancy, leaving only the informational content. The measure of information of a source message  $a_i$  (in bits) is  $-\log p(a_i)$ , where  $\log$  denotes the base 2 logarithm and  $p(a_i)$  denotes the probability of occurrence of the message  $a_i$ .<sup>2</sup> This definition has intuitive appeal; in the case in which  $p(a_i) = 1$ , it is clear that  $a_i$  is not at all informative since it had to occur. Similarly, the smaller the value of  $p(a_i)$ , the more unlikely  $a_i$  is to appear, and hence the larger its information content. The reader is referred to Abramson [1963, pp. 6–13] for a longer, more elegant discussion of the legitimacy of this technical definition of the concept of information. The average information content over the source alphabet can be computed by weighting the information content of each source letter by its probability of occurrence, yielding the expression  $\sum_{i=1}^n [-p(a_i) \log p(a_i)]$ . This quantity is referred to as the entropy of a source letter or the entropy of the source and is denoted by  $H$ . Since the length of a codeword for message  $a_i$  must be sufficient to carry the information content of  $a_i$ , entropy imposes a lower bound on the number of bits required for the coded message. The total number of

<sup>2</sup> Note that throughout this paper all logarithms are to the base 2.

bits must be at least as large as the product of  $H$  and the length of the source ensemble. Since the value of  $H$  is generally not an integer, variable-length codewords must be used if the lower bound is to be achieved. Given that message *EXAMPLE* is to be encoded one letter at a time, the entropy of its source can be calculated using the probabilities given in Figure 3:  $H = 2.894$ , so that the minimum number of bits contained in an encoding of *EXAMPLE* is 116. The Huffman code given in Section 1.2 does not quite achieve the theoretical minimum in this case.

Both of these definitions of information content are due to Shannon [1949]. A derivation of the concept of entropy as it relates to information theory is presented by Shannon [1949]. A simpler, more intuitive explanation of entropy is offered by Ash [1965].

The most common notion of a “good” code is one that is *optimal* in the sense of having minimum redundancy. *Redundancy* can be defined as  $\sum p(a_i)l_i - \sum [-p(a_i)\log p(a_i)]$ , where  $l_i$  is the length of the codeword representing message  $a_i$ . The expression  $\sum p(a_i)l_i$  represents the lengths of the codewords weighted by their probabilities of occurrence, that is, the average codeword length. The expression  $\sum [-p(a_i)\log p(a_i)]$  is entropy  $H$ . Thus, redundancy is a measure of the difference between average codeword length and average information content. If a code has minimum average codeword length for a given discrete probability distribution, it is said to be a *minimum redundancy* code.

We define the term *local redundancy* to capture the notion of redundancy caused by local properties of a message ensemble, rather than its global characteristics. Although the model used for analyzing general-purpose coding techniques assumes a random distribution of the source messages, this may not actually be the case. In particular applications the tendency for messages to cluster in predictable patterns may be known. The existence of predictable patterns may be exploited to minimize local redundancy. Examples of applications in which local redundancy is common and

methods for dealing with local redundancy are discussed in Sections 2 and 6.2.

Huffman uses *average message length*,  $\sum p(a_i)l_i$ , as a measure of the efficiency of a code. Clearly, the meaning of this term is the average length of a *coded* message. We use the term *average codeword length* to represent this quantity. Since redundancy is defined to be average codeword length minus entropy and entropy is constant for a given probability distribution, minimizing average codeword length minimizes redundancy.

A code is *asymptotically optimal* if it has the property that for a given probability distribution, the ratio of average codeword length to entropy approaches 1 as entropy tends to infinity. That is, asymptotic optimality guarantees that average codeword length approaches the theoretical minimum (entropy represents information content, which imposes a lower bound on codeword length).

The amount of compression yielded by a coding scheme can be measured by a *compression ratio*. Compression ratio has been defined in several ways. The definition  $C = (\text{average message length})/(\text{average codeword length})$  captures the common meaning, which is a comparison of the length of the coded message to the length of the original ensemble [Cappellini 1985]. If we think of the characters of the ensemble *EXAMPLE* as 6-bit ASCII characters, then the average message length is 6 bits. The Huffman code of Section 1.2 represents *EXAMPLE* in 117 bits, or 2.9 bits per character. This yields a compression ratio of 6/2.9, representing compression by a factor of more than 2. Alternatively, we may say that Huffman encoding produces a file whose size is 49% of the original ASCII file, or that 49% compression has been achieved.

A somewhat different definition of compression ratio by Rubin [1976],  $C = (S - O - OR)/S$ , includes the representation of the code itself in the transmission cost. In this definition,  $S$  represents the length of the source ensemble,  $O$  the length of the output (coded message), and  $OR$  the size of the “output representation” (e.g., the

number of bits required for the encoder to transmit the code mapping to the decoder). The quantity *OR* constitutes a "charge" to an algorithm for transmission of information about the coding scheme. The intention is to measure the total size of the transmission (or file to be stored).

#### 1.4 Motivation

As discussed in the Introduction, data compression has wide application in terms of information storage, including representation of the abstract data type *string* [Standish 1980] and file compression. Huffman coding is used for compression in several file archival systems [ARC 1986; PKARC 1987], as is Lempel-Ziv coding, one of the adaptive schemes to be discussed in Section 5. An adaptive Huffman coding technique is the basis for the *compact* command of the UNIX operating system, and the UNIX *compress* utility employs the Lempel-Ziv approach [UNIX 1984].

In the area of data transmission, Huffman coding has been passed over for years in favor of block-block codes, notably ASCII. The advantage of Huffman coding is in the average number of bits per character transmitted, which may be much smaller than the  $\log n$  bits per character (where  $n$  is the source alphabet size) of a block-block system. The primary difficulty associated with variable-length codewords is that the rate at which bits are presented to the transmission channel will fluctuate, depending on the relative frequencies of the source messages. This fluctuation requires buffering between the source and the channel. Advances in technology have both overcome this difficulty and contributed to the appeal of variable-length codes. Current data networks allocate communication resources to sources on the basis of need and provide buffering as part of the system. These systems require significant amounts of protocol, and fixed-length codes are quite inefficient for applications such as packet headers. In addition, communication costs are beginning to dominate storage and processing costs, so that variable-length coding schemes that reduce communication costs are attractive even if they are more

complex. For these reasons, one could expect to see even greater use of variable-length coding in the future.

It is interesting to note that the Huffman coding algorithm, originally developed for the efficient transmission of data, also has a wide variety of applications outside the sphere of data compression. These include construction of optimal search trees [Zimmerman 1959; Hu and Tucker 1971; Itai 1976], list merging [Brent and Kung 1978], and generating optimal evaluation trees in the compilation of expressions [Parker 1980]. Additional applications involve search for jumps in a monotone function of a single variable, sources of pollution along a river, and leaks in a pipeline [Glassey and Karp 1976]. The fact that this elegant combinatorial algorithm has influenced so many diverse areas underscores its importance.

## 2. SEMANTIC-DEPENDENT METHODS

Semantic-dependent data compression techniques are designed to respond to specific types of local redundancy occurring in certain applications. One area in which data compression is of great importance is image representation and processing. There are two major reasons for this. The first is that digitized images contain a large amount of local redundancy. An image is usually captured in the form of an array of pixels, whereas methods that exploit the tendency for pixels of like color or intensity to cluster together may be more efficient. The second reason for the abundance of research in this area is volume. Digital images usually require a very large number of bits, and many uses of digital images involve large collections of images.

One technique used for compression of image data is *run-length encoding*. In a common version of run-length encoding, the sequence of image elements along a scan line (row)  $x_1, x_2, \dots, x_n$  is mapped into a sequence of pairs  $(c_1, l_1), (c_2, l_2), \dots, (c_k, l_k)$ , where  $c_i$  represents an intensity or color and  $l_i$  the length of the  $i$ th run (sequence of pixels of equal intensity). For pictures such as weather maps, run-length encoding can save a significant number of



bits over the image element sequence [Gonzalez and Wintz 1977].

Another data compression technique specific to the area of image data is *difference mapping*, in which the image is represented as an array of differences in brightness (or color) between adjacent pixels rather than the brightness values themselves. Difference mapping was used to encode the pictures of Uranus transmitted by *Voyager 2*. The 8 bits per pixel needed to represent 256 brightness levels was reduced to an average of 3 bits per pixel when difference values were transmitted [Laeser et al. 1986]. In spacecraft applications, image fidelity is a major concern because of the effect of the distance from the spacecraft to Earth on transmission reliability. Difference mapping was combined with error-correcting codes to provide both compression and data integrity in the *Voyager 2* project. Another method that takes advantage of the tendency for images to contain large areas of constant intensity is the use of the quadtree data structure [Samet 1984]. Additional examples of coding techniques used in image processing can be found in Wilkins and Wintz [1971] and in Cappellini [1985].

Data compression is of interest in business data processing, because of both the cost savings it offers and the large volume of data manipulated in many business applications. The types of local redundancy present in business data files include runs of zeros in numeric fields, sequences of blanks in alphanumeric fields, and fields that are present in some records and null in others. Run-length encoding can be used to compress sequences of zeros or blanks. Null suppression can be accomplished through the use of presence bits [Ruth and Kretzner 1972]. Another class of methods exploits cases in which only a limited set of attribute values exist. *Dictionary substitution* entails replacing alphanumeric representations of information such as bank account type, insurance policy type, sex, and month by the few bits necessary to represent the limited number of possible attribute values [Reghbati 1981].

Cormack [1985] describes a data compression system that is designed for use

with database files. The method, which is part of IBM's Information Management System (IMS), compresses individual records and is invoked each time a record is stored in the database file; expansion is performed each time a record is retrieved. Since records may be retrieved in any order, context information used by the compression routine is limited to a single record. In order for the routine to be applicable to any database, it must be able to adapt to the format of the record. The fact that database records are usually heterogeneous collections of small fields indicates that the local properties of the data are more important than their global characteristics. The compression routine in IMS is a hybrid method that attacks this local redundancy by using different coding schemes for different types of fields. The identified field types in IMS are *letters of the alphabet*, *numeric digits*, *packed decimal digit pairs*, *blank*, and *other*. When compression begins, a default code is used to encode the first character of the record. For each subsequent character, the type of the previous character determines the code to be used. For example, if the record "01870**b**ABCD**b**bLMN" were encoded with the *letter* code as default, the leading zero would be coded using the *letter* code; the 1, 8, 7, 0 and the first blank (**b**) would be coded by the *numeric* code. The A would be coded by the *blank* code; B, C, D, and the next blank by the *letter* code; the next blank and the L by the *blank* code; and the M and N by the *letter* code. Clearly, each code must define a codeword for every character; the *letter* code would assign the shortest codewords to letters, the numeric code would favor the digits, and so on. In the system Cormack describes, the types of the characters are stored in the encode/decode data structures. When a character *c* is received, the decoder checks *type(c)* to detect which code table will be used in transmitting the next character. The compression algorithm might be more efficient if a special bit string were used to alert the receiver to a change in code table. Particularly if fields were reasonably long, decoding would be more rapid and the extra bits in the transmission would not be excessive.

Cormack reports that the performance of the IMS compression routines is very good; at least 50 sites are currently using the system. He cites a case of a database containing student records whose size was reduced by 42.1%, and as a side effect the number of disk operations required to load the database was reduced by 32.7% [Cormack 1985].

A variety of approaches to data compression designed with text files in mind includes use of a dictionary representing either all of the words in the file so that the file itself is coded as a list of pointers to the dictionary [Hahn 1974], or common words and word endings so that the file consists of pointers to the dictionary and encodings of the less common words [Tropper 1982]. Hand selection of common phrases [Wagner 1973], programmed selection of prefixes and suffixes [Fraenkel et al. 1983], and programmed selection of common character pairs [Cortesi 1982; Snyderman and Hunt 1970] have also been investigated.

This discussion of semantic-dependent data compression techniques represents a limited sample of a very large body of research. These methods and others of a like nature are interesting and of great value in their intended domains. Their obvious drawback lies in their limited utility. It should be noted, however, that much of the efficiency gained through the use of semantic-dependent techniques can be achieved through more general methods, albeit to a lesser degree. For example, the dictionary approaches can be implemented through either Huffman coding (Sections 3.2 and 4) or Lempel-Ziv codes (Section 5.1). Cormack's database scheme is a special case of the codebook approach (Section 3.2), and run-length encoding is one of the effects of Lempel-Ziv codes.

### 3. STATIC DEFINED-WORDS SCHEMES

The classic defined-word scheme was developed over 30 years ago in Huffman's well-known paper on minimum-redundancy coding [Huffman 1952]. Huffman's algorithm provided the first solution to the problem of constructing minimum-redundancy codes. Many people

believe that Huffman coding cannot be improved upon; that is, that it is guaranteed to achieve the best possible compression ratio. This is only true, however, under the constraints that each source message is mapped to a unique codeword and that the compressed text is the concatenation of the codewords for the source messages. An earlier algorithm, due independently to Shannon and Fano [Shannon and Weaver 1949; Fano 1949], is not guaranteed to provide optimal codes but approaches optimal behavior as the number of messages approaches infinity. The Huffman algorithm is also of importance because it has provided a foundation upon which other data compression techniques have been built and a benchmark to which they may be compared. We classify the codes generated by the Huffman and Shannon-Fano algorithms as variable-variable and note that they include block-variable codes as a special case, depending on how the source messages are defined. Shannon-Fano coding is discussed in Section 3.1; Huffman coding in Section 3.2.

In Section 3.3 codes that map the integers onto binary codewords are discussed. Since any finite alphabet may be enumerated, this type of code has general-purpose utility. However, a more common use of these codes (called universal codes) is in conjunction with an adaptive scheme. This connection is discussed in Section 5.2.

Arithmetic coding, presented in Section 3.4, takes a significantly different approach to data compression from that of the other static methods. It does not construct a code, in the sense of a mapping from source messages to codewords. Instead, arithmetic coding replaces the source ensemble by a code string that, unlike all the other codes discussed here, is not the concatenation of codewords corresponding to individual source messages. Arithmetic coding is capable of achieving compression results that are arbitrarily close to the entropy of the source.

#### 3.1 Shannon-Fano Coding

The Shannon-Fano technique has as an advantage its simplicity. The code is constructed as follows: The source messages  $a_i$

$a_1$	1/2	0	step 1
$a_2$	1/4	10	step 2
$a_3$	1/8	110	step 3
$a_4$	1/16	1110	step 4
$a_5$	1/32	11110	step 5
$a_6$	1/32	11111	

Figure 5. A Shannon-Fano code.

$g$	8/40	00	step 2
$f$	7/40	010	step 3
$e$	6/40	011	step 1
$d$	5/40	100	step 5
$space$	5/40	101	step 4
$c$	4/40	110	step 6
$b$	3/40	1110	step 7
$a$	2/40	1111	

Figure 6. A Shannon-Fano code for *EXAMPLE* (code length = 117).

and their probabilities  $p(a_i)$  are listed in order of nonincreasing probability. This list is then divided in such a way as to form two groups of as nearly equal total probabilities as possible. Each message in the first group receives 0 as the first digit of its codeword; the messages in the second half have codewords beginning with 1. Each of these groups is then divided according to the same criterion, and additional code digits are appended. The process is continued until each subset contains only one message. Clearly, the Shannon-Fano algorithm yields a minimal prefix code.

Figure 5 shows the application of the method to a particularly simple probability distribution. The length of each codeword is equal to  $-\log p(a_i)$ . This is true as long as it is possible to divide the list into subgroups of exactly equal probability. When this is not possible, some codewords may be of length  $-\log p(a_i) + 1$ . The Shannon-Fano algorithm yields an average codeword length  $S$  that satisfies  $H \leq S \leq H + 1$ . In Figure 6, the Shannon-Fano code for ensemble *EXAMPLE* is given. As is often the case, the average codeword length

is the same as that achieved by the Huffman code (see Figure 3). That the Shannon-Fano algorithm is not guaranteed to produce an optimal code is demonstrated by the following set of probabilities:  $\{.35, .17, .17, .16, .15\}$ . The Shannon-Fano code for this distribution is compared with the Huffman code in Section 3.2.

### 3.2 Static Huffman Coding

Huffman's algorithm, expressed graphically, takes as input a list of nonnegative weights  $\{w_1, \dots, w_n\}$  and constructs a full binary tree<sup>3</sup> whose leaves are labeled with the weights. When the Huffman algorithm is used to construct a code, the weights represent the probabilities associated with the source letters. Initially, there is a set of singleton trees, one for each weight in the list. At each step in the algorithm the trees corresponding to the two smallest weights,  $w_i$  and  $w_j$ , are merged into a new tree whose weight is  $w_i + w_j$  and whose root has two children that are the subtrees represented by  $w_i$  and  $w_j$ . The weights  $w_i$  and  $w_j$  are removed from the list, and  $w_i + w_j$  is inserted into the list. This process continues until the weight list contains a single value. If, at any time, there is more than one way to choose a smallest pair of weights, any such pair may be chosen. In Huffman's paper the process begins with a nonincreasing list of weights. This detail is not important to the correctness of the algorithm, but it does provide a more efficient implementation [Huffman 1952]. The Huffman algorithm is demonstrated in Figure 7.

The Huffman algorithm determines the lengths of the codewords to be mapped to each of the source letters  $a_i$ . There are many alternatives for specifying the actual digits; it is necessary only that the code have the prefix property. The usual assignment entails labeling the edge from each parent to its left child with the digit 0 and the edge to the right child with 1. The codeword for each source letter is the sequence of labels along the path from the root to the leaf node representing that letter. The codewords for the source of

<sup>3</sup> A binary tree is full if every node has either zero or two children.

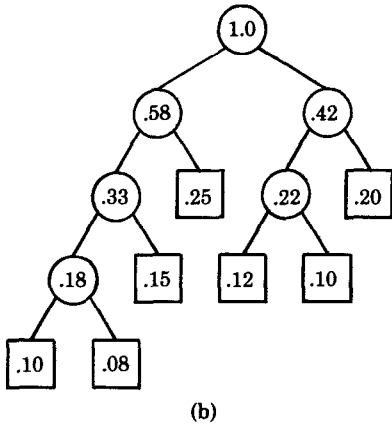
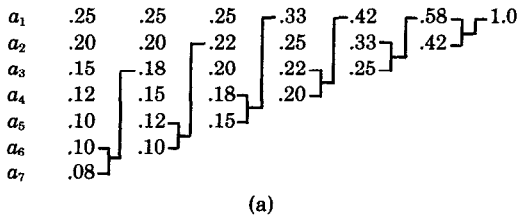

Figure 7. The Huffman process: (a) The list; (b) the tree.

Figure 7, in order of decreasing probability, are {01, 11, 001, 100, 101, 0000, 0001}. Clearly, this process yields a minimal prefix code. Further, the algorithm is guaranteed to produce an *optimal* (minimum redundancy) code [Huffman 1952]. Gallager [1978] has proved an upper bound on the redundancy of a Huffman code of  $p_n + \log[(2 \log e)/e] \approx p_n + 0.086$ , where  $p_n$  is the probability of the least likely source message. In a recent paper, Capocelli et al. [1986] have provided new bounds that are tighter than those of Gallager for some probability distributions. Figure 8 shows a distribution for which the Huffman code is optimal while the Shannon-Fano code is not.

In addition to the fact that there are many ways of forming codewords of appropriate lengths, there are cases in which the Huffman algorithm does not uniquely determine these lengths owing to the arbitrary choice among equal minimum weights. As an example, codes with codeword lengths of {1, 2, 3, 4, 4} and {2, 2, 2, 3,

		S-F	Huffman
$a_1$	0.35	00	1
$a_2$	0.17	01	011
$a_3$	0.17	10	010
$a_4$	0.16	110	001
$a_6$	0.15	111	000
Average codeword length		2.31	2.30

Figure 8. Comparison of Shannon-Fano and Huffman codes.

3} both yield the same average codeword length for a source with probabilities { .4, .2, .2, .1, .1}. Schwartz [1964] defines a variation of the Huffman algorithm that performs "bottom merging", that is, that orders a new parent node above existing nodes of the last two weights in the list. The code constructed is the Huffman code with minimum values of maximum codeword length ( $\max\{l_i\}$ ) and total codeword length ( $\sum l_i$ ). Schwartz and Kallick [1964] describe an implementation of Huffman's algorithm with bottom merging. The Schwartz-Kallick algorithm and a later algorithm by Connell [1973] use Huffman's procedure to determine the lengths of the codewords, and actual digits are assigned so that the code has the *numerical sequence property*; that is, codewords of equal length form a consecutive sequence of binary numbers. Shannon-Fano codes also have the numerical sequence property. This property can be exploited to achieve a compact representation of the code and rapid encoding and decoding.

Both the Huffman and the Shannon-Fano mappings can be generated in  $O(n)$  time, where  $n$  is the number of messages in the source ensemble (assuming that the weights have been presorted). Each of these algorithms maps a source message  $a_i$  with probability  $p$  to a codeword of length  $l$  ( $-\log p \leq l \leq -\log p + 1$ ). Encoding and decoding times depend on the representation of the mapping. If the mapping is stored as a binary tree, then decoding the codeword for  $a_i$  involves following a path of length  $l$  in the tree. A table indexed by the source messages could be used for encoding; the code for  $a_i$  would be stored in position

$i$  of the table and encoding time would be  $O(l)$ . Connell's algorithm makes use of the *index* of the Huffman code, a representation of the distribution of codeword lengths, to encode and decode in  $O(c)$  time, where  $c$  is the number of different codeword lengths. Tanaka [1987] presents an implementation of Huffman coding based on finite-state machines that can be realized efficiently in either hardware or software.

As noted earlier, the redundancy bound for Shannon-Fano codes is 1 and the bound for the Huffman method is  $p_n + 0.086$ , where  $p_n$  is the probability of the least likely source message (so  $p_n$  is less than or equal to .5, and generally much less). It is important to note that in defining redundancy to be average codeword length minus entropy, the cost of transmitting the code mapping computed by these algorithms is ignored. The overhead cost for any method in which the source alphabet has not been established before transmission includes  $n \log n$  bits for sending the  $n$  source letters. For a Shannon-Fano code, a list of codewords ordered so as to correspond to the source letters could be transmitted. The additional time required is then  $\sum l_i$ , where the  $l_i$  are the lengths of the codewords. For Huffman coding, an encoding of the shape of the code tree might be transmitted. Since any full binary tree may be a legal Huffman code tree, encoding tree shape may require as many as  $\log 4^n = 2n$  bits. In most cases the message ensemble is very large, so that the number of bits of overhead is minute by comparison to the total length of the encoded transmission. However, it is imprudent to ignore this cost.

If a less-than-optimal code is acceptable, the overhead costs can be avoided through a prior agreement by sender and receiver as to the code mapping. Instead of a Huffman code based on the characteristics of the current message ensemble, the code used could be based on statistics for a class of transmissions to which the current ensemble is assumed to belong. That is, both sender and receiver could have access to a *codebook* with  $k$  mappings in it: one for Pascal source, one for English text, and so on. The sender would then simply alert the receiver as to which of the common codes

he or she is using. This requires only  $\log k$  bits of overhead. Assuming that classes of transmission with relatively stable characteristics could be identified, this hybrid approach would greatly reduce the redundancy due to overhead without significantly increasing expected codeword length. In addition, the cost of computing the mapping would be amortized over all files of a given class. That is, the mapping would be computed once on a statistically significant sample and then used on a great number of files for which the sample is representative. There is clearly a substantial risk associated with assumptions about file characteristics, and great care would be necessary in choosing both the sample from which the mapping is to be derived and the categories into which to partition transmissions. An extreme example of the risk associated with the codebook approach is provided by Ernest V. Wright who wrote the novel *Gadsby* (1939) containing no occurrences of the letter E. Since E is the most commonly used letter in the English language, an encoding based on a sample from *Gadsby* would be disastrous if used with "normal" examples of English text. Similarly, the "normal" encoding would provide poor compression of *Gadsby*.

McIntyre and Pechura [1985] describe an experiment in which the codebook approach is compared to static Huffman coding. The sample used for comparison is a collection of 530 source programs in four languages. The codebook contains a Pascal code tree, a FORTRAN code tree, a COBOL code tree, a PL/I code tree, and an ALL code tree. The Pascal code tree is the result of applying the static Huffman algorithm to the combined character frequencies of all of the Pascal programs in the sample. The ALL code tree is based on the combined character frequencies for all of the programs. The experiment involves encoding each of the programs using the five codes in the codebook and the static Huffman algorithm. The data reported for each of the 530 programs consist of the size of the coded program for each of the five predetermined codes and the size of the coded program plus the size of the mapping (in table form) for the static Huffman

method. In every case the code tree for the language class to which the program belongs generates the most compact encoding. Although using the Huffman algorithm on the program itself yields an optimal mapping, the overhead cost is greater than the added redundancy incurred by the less-than-optimal code. In many cases, the ALL code tree also generates a more compact encoding than the static Huffman algorithm. In the worst case an encoding constructed from the codebook is only 6.6% larger than that constructed by the Huffman algorithm. These results suggest that, for files of source code, the codebook approach may be appropriate.

Gilbert [1971] discusses the construction of Huffman codes based on inaccurate source probabilities. A simple solution to the problem of incomplete knowledge of the source is to avoid long codewords, thereby minimizing the error of badly underestimating the probability of a message. The problem becomes one of constructing the optimal binary tree subject to a height restriction (see [Knuth 1971; Hu and Tan 1972; Garey 1974]). Another approach involves collecting statistics for several sources and then constructing a code based on some combined criterion. This approach could be applied to the problem of designing a single code for use with English, French, German, and so on, sources. To accomplish this, Huffman's algorithm could be used to minimize either the average codeword length for the combined source probabilities or the average codeword length for English, subject to constraints on average codeword lengths for the other sources.

### 3.3 Universal Codes and Representations of the Integers

A code is *universal* if it maps source messages to codewords so that the resulting average codeword length is bounded by  $c_1H + c_2$ . That is, given an arbitrary source with nonzero entropy, a universal code achieves average codeword length that is at most a constant times the optimal possible for that source. The potential compression offered by a universal code clearly depends on the magnitudes of the

constants  $c_1$  and  $c_2$ . We recall the definition of an asymptotically optimal code as one for which average codeword length approaches entropy and remark that a universal code with  $c_1 = 1$  is asymptotically optimal.

An advantage of universal codes over Huffman codes is that it is not necessary to know the exact probabilities with which the source messages appear. Whereas Huffman coding is not applicable unless the probabilities are known, with universal coding it is sufficient to know the probability distribution only to the extent that the source messages can be ranked in probability order. By mapping messages in order of decreasing probability to codewords in order of increasing length, universality can be achieved. Another advantage to universal codes is that the codeword sets are fixed. It is not necessary to compute a codeword set based on the statistics of an ensemble; any universal codeword set will suffice as long as the source messages are ranked. The encoding and decoding processes are thus simplified. Although universal codes can be used instead of Huffman codes as general-purpose static schemes, the more common application is as an adjunct to a dynamic scheme. This type of application is demonstrated in Section 5.

Since the ranking of source messages is the essential parameter in universal coding, we may think of a universal code as representing an enumeration of the source messages or as representing the integers, which provide an enumeration. Elias [1975] defines a sequence of universal coding schemes that maps the set of positive integers onto the set of binary codewords.

The first Elias code is one that is simple but not optimal. This code,  $\gamma$ , maps an integer  $x$  onto the binary value of  $x$  prefaced by  $\lfloor \log x \rfloor$  zeros. The binary value of  $x$  is expressed in as few bits as possible and therefore begins with a 1, which serves to delimit the prefix. The result is an instantaneously decodable code since the total length of a codeword is exactly one greater than twice the number of zeros in the prefix; therefore, as soon as the first 1 of a codeword is encountered, its length is known. The code is not a minimum

	$\gamma$	$\delta$
1	1	1
2	010	0100
3	011	0101
4	00100	01100
5	00101	01101
6	00110	01110
7	00111	01111
8	0001000	00100000
16	000010000	001010000
17	000010001	001010001
32	00000100000	0011000000

Figure 9. Elias codes.

redundancy code since the ratio of expected codeword length to entropy goes to 2 as entropy approaches infinity. The second code,  $\delta$ , maps an integer  $x$  to a codeword consisting of  $\gamma(\lfloor \log x \rfloor + 1)$  followed by the binary value of  $x$  with the leading 1 deleted. The resulting codeword has length  $\lfloor \log x \rfloor + 2\lfloor \log(1 + \lfloor \log x \rfloor) \rfloor + 1$ . This concept can be applied recursively to shorten the codeword lengths, but the benefits decrease rapidly. The code  $\delta$  is asymptotically optimal since the limit of the ratio of expected codeword length to entropy is 1. Figure 9 lists the values of  $\gamma$  and  $\delta$  for a sampling of the integers. Figure 10 shows an Elias code for string *EXAMPLE*. The number of bits transmitted using this mapping would be 161, which does not compare well with the 117 bits transmitted by the Huffman code of Figure 3. Huffman coding is optimal under the static mapping model. Even an asymptotically optimal universal code cannot compare with static Huffman coding on a source for which the probabilities of the messages are known.

A second sequence of universal coding schemes, based on the Fibonacci numbers, is defined by Apostolico and Fraenkel [1985]. Although the Fibonacci codes are not asymptotically optimal, they compare well to the Elias codes as long as the number of source messages is not too large. Fibonacci codes have the additional attribute of robustness, which manifests itself by the local containment of errors. This aspect of Fibonacci codes is discussed further in Section 7.

The sequence of Fibonacci codes described by Apostolico and Fraenkel is based

Source message	Frequency	Rank	Codeword
<i>g</i>	8	1	$\delta(1) = 1$
<i>f</i>	7	2	$\delta(2) = 0100$
<i>e</i>	6	3	$\delta(3) = 0101$
<i>d</i>	5	4	$\delta(4) = 01100$
<i>space</i>	5	5	$\delta(5) = 01101$
<i>c</i>	4	6	$\delta(6) = 01110$
<i>b</i>	3	7	$\delta(7) = 01111$
<i>a</i>	2	8	$\delta(8) = 00100000$

Figure 10. An Elias code for *EXAMPLE* (code length = 161).

on the Fibonacci numbers of order  $m \geq 2$ , where the Fibonacci numbers of order 2 are the standard Fibonacci numbers: 1, 1, 2, 3, 5, 8, 13, . . . . In general, the Fibonacci numbers of order  $m$  are defined by the recurrence: Fibonacci numbers  $F_{-m+1}$  through  $F_0$  are equal to 1; the  $k$ th number for  $k \geq 1$  is the sum of the preceding  $m$  numbers. We describe only the order-2 Fibonacci code; the extension to higher orders is straightforward.

Every nonnegative integer  $N$  has precisely one binary representation of the form  $R(N) = \sum_{i=0}^k d_i F_i$  (where  $d_i \in \{0, 1\}$ ,  $k \leq N$ , and the  $F_i$  are the order-2 Fibonacci numbers as defined above) such that there are no adjacent ones in the representation. The Fibonacci representations for a small sampling of the integers are shown in Figure 11, using the standard bit sequence from high order to low. The bottom row of the figure gives the values of the bit positions. It is immediately obvious that this Fibonacci representation does not constitute a prefix code. The order-2 Fibonacci code for  $N$  is defined as  $F(N) = D1$ , where  $D = d_0 d_1 d_2 \dots d_k$  (the  $d_i$  defined above). That is, the Fibonacci representation is reversed and 1 is appended. The Fibonacci code values for a small subset of the integers are given in Figure 11. These binary codewords form a prefix code since every codeword now terminates in two consecutive ones, which cannot appear anywhere else in a codeword.

Fraenkel and Klein [1985] prove that the Fibonacci code of order 2 is universal, with  $c_1 = 2$  and  $c_2 = 3$ . It is not asymptotically optimal since  $c_1 > 1$ . Fraenkel and Klein

$N$	$R(N)$	$F(N)$
1		1 11
2		1 0 011
3	1 0 0	0011
4	1 0 1	1011
5	1 0 0 0	00011
6	1 0 0 1	10011
7	1 0 1 0	01011
8	1 0 0 0 0	000011
16	1 0 0 1 0 0	0010011
32	1 0 1 0 1 0 0	00101011
	21 13 8 5 3 2 1	

Figure 11. Fibonacci representations and Fibonacci codes.

Source message	Frequency	Rank	Codeword
<i>g</i>	8	1	$F(1) = 11$
<i>f</i>	7	2	$F(2) = 011$
<i>e</i>	6	3	$F(3) = 0011$
<i>d</i>	5	4	$F(4) = 1011$
<i>space</i>	5	5	$F(5) = 00011$
<i>c</i>	4	6	$F(6) = 10011$
<i>b</i>	3	7	$F(7) = 01011$
<i>a</i>	2	8	$F(8) = 000011$

Figure 12. A Fibonacci code for *EXAMPLE* (code length = 153).

also show that Fibonacci codes of higher order compress better than the order-2 code if the source language is large enough (i.e., the number of distinct source messages is large) and the probability distribution is nearly uniform. However, no Fibonacci code is asymptotically optimal. The Elias codeword  $\delta(N)$  is asymptotically shorter than any Fibonacci codeword for  $N$ , but the integers in a very large initial range have shorter Fibonacci codewords. For  $m = 2$ , for example, the transition point is  $N = 514,228$  [Apostolico and Fraenkel 1985]. Thus, a Fibonacci code provides better compression than the Elias code until the size of the source language becomes very large. Figure 12 shows a Fibonacci code for string *EXAMPLE*. The number of bits transmitted using this mapping would be 153, which is an improvement over the Elias code of Figure 10, but still compares poorly with the Huffman code of Figure 3.

Source message	Probability	Cumulative probability	Range
<i>A</i>	.2	.2	[0, .2)
<i>B</i>	.4	.6	[.2, .6)
<i>C</i>	.1	.7	[.6, .7)
<i>D</i>	.2	.9	[.7, .9)
#	.1	1.0	[.9, 1.0)

Figure 13. The arithmetic coding model.

### 3.4 Arithmetic Coding

The method of arithmetic coding was suggested by Elias and presented by Abramson [1963] in his text on information theory. Implementations of Elias' technique were developed by Rissanen [1976], Pasco [1976], Rubin [1979], and, most recently, Witten et al. [1987]. We present the concept of arithmetic coding first and follow with a discussion of implementation details and performance.

In arithmetic coding a source ensemble is represented by an interval between 0 and 1 on the real number line. Each symbol of the ensemble narrows this interval. As the interval becomes smaller, the number of bits needed to specify it grows. Arithmetic coding assumes an explicit probabilistic model of the source. It is a defined-word scheme that uses the probabilities of the source messages to successively narrow the interval used to represent the ensemble. A high-probability message narrows the interval less than a low-probability message, so that high-probability messages contribute fewer bits to the coded message. The method begins with an unordered list of source messages and their probabilities. The number line is partitioned into subintervals on the basis of cumulative probabilities.

A small example is used to illustrate the idea of arithmetic coding. Given source messages  $\{A, B, C, D, \#\}$  with probabilities  $\{.2, .4, .1, .2, .1\}$ , Figure 13 demonstrates the initial partitioning of the number line. The symbol *A* corresponds to the first  $\frac{1}{5}$  of the interval  $[0, 1)$ ; *B* the next  $\frac{2}{5}$ ; *D* the subinterval of size  $\frac{1}{5}$ , which begins 70% of the way from the left endpoint to the right. When encoding begins, the source ensemble is represented by the entire interval  $[0, 1)$ . For the ensemble *AADB#*, the first



A reduces the interval to  $[0, .2)$  and the second A to  $[0, .04)$  (the first  $\frac{1}{5}$  of the previous interval). The D further narrows the interval to  $[\text{.028}, \text{.036})$  ( $\frac{1}{5}$  of the previous size, beginning 70% of the distance from left to right). The B narrows the interval to  $[\text{.0296}, \text{.0328})$ , and the # yields a final interval of  $[\text{.03248}, \text{.0328})$ . The interval, or alternatively any number  $i$  within the interval, may now be used to represent the source ensemble.

Two equations may be used to define the narrowing process described above:

$$\text{newleft} = \text{prevleft} + \text{msgleft} * \text{prevsize} \quad (1)$$

$$\text{newsize} = \text{prevsize} * \text{msgsize} \quad (2)$$

Equation (1) states that the left endpoint of the new interval is calculated from the previous interval and the current source message. The left endpoint of the range associated with the current message specifies what percent of the previous interval to remove from the left in order to form the new interval. For D in the above example, the new left endpoint is moved over by  $.7 \times .04$  (70% of the size of the previous interval). Equation (2) computes the size of the new interval from the previous interval size and the probability of the current message (which is equivalent to the size of its associated range). Thus, the size of the interval determined by D is  $.04 \times .2$ , and the right endpoint is  $.028 + .008 = .036$  (left endpoint + size).

The size of the final subinterval determines the number of bits needed to specify a number in that range. The number of bits needed to specify a subinterval of  $[0, 1)$  of size  $s$  is  $-\log s$ . Since the size of the final subinterval is the product of the probabilities of the source messages in the ensemble (i.e.,  $s = \prod_{i=1}^N p(\text{source message } i)$ , where  $N$  is the length of the ensemble), we have  $-\log s = -\sum_{i=1}^N \log p(\text{source message } i) = -\sum_{i=1}^n p(a_i) \log p(a_i)$ , where  $n$  is the number of unique source messages  $a_1, a_2, \dots, a_n$ . Thus, the number of bits generated by the arithmetic coding technique is exactly equal to entropy  $H$ . This demonstrates the fact that arithmetic coding achieves compression that is almost exactly that predicted by the entropy of the source.

In order to recover the original ensemble, the decoder must know the model of the source used by the encoder (e.g., the source messages and associated ranges) and a single number within the interval determined by the encoder. Decoding consists of a series of comparisons of the number  $i$  to the ranges representing the source messages. For this example,  $i$  might be  $.0325$  ( $.03248, .0326$ , or  $.0327$  would all do just as well). The decoder uses  $i$  to simulate the actions of the encoder. Since  $i$  lies between 0 and  $.2$ , the decoder deduces that the first letter was A (since the range  $[0, .2)$  corresponds to source message A). This narrows the interval to  $[0, .2)$ . The decoder can now deduce that the next message will further narrow the interval in one of the following ways: to  $[0, .04)$  for A, to  $[\text{.04}, \text{.12})$  for B, to  $[\text{.12}, \text{.14})$  for C, to  $[\text{.14}, \text{.18})$  for D, or to  $[\text{.18}, \text{.2})$  for #. Since  $i$  falls into the interval  $[0, .04)$ , the decoder knows that the second message is again A. This process continues until the entire ensemble has been recovered.

Several difficulties become evident when implementation of arithmetic coding is attempted. The first is that the decoder needs some way of knowing when to stop. As evidence of this, the number 0 could represent any of the source ensembles A, AA, AAA, and so forth. Two solutions to this problem have been suggested. One is that the encoder transmit the size of the ensemble as part of the description of the model. Another is that a special symbol be included in the model for the purpose of signaling end of message. The # in the above example serves this purpose. The second alternative is preferable for several reasons. First, sending the size of the ensemble requires a two-pass process and precludes the use of arithmetic coding as part of a hybrid codebook scheme (see Sections 1.2 and 3.2). Second, adaptive methods of arithmetic coding are easily developed, and a first pass to determine ensemble size is inappropriate in an on-line adaptive scheme.

A second issue left unresolved by the fundamental concept of arithmetic coding is that of incremental transmission and reception. It appears from the above

discussion that the encoding algorithm transmits nothing until the final interval is determined. However, this delay is not necessary. As the interval narrows, the leading bits of the left and right endpoints become the same. Any leading bits that are the same may be transmitted immediately, since they will not be affected by further narrowing. A third issue is that of precision. From the description of arithmetic coding it appears that the precision required grows without bound as the length of the ensemble grows. Witten et al. [1987] and Rubin [1979] address this issue. Fixed precision registers may be used as long as underflow and overflow are detected and managed. The degree of compression achieved by an implementation of arithmetic coding is not exactly  $H$ , as implied by the concept of arithmetic coding. Both the use of a message terminator and the use of fixed-length arithmetic reduce coding effectiveness. However, it is clear that an end-of-message symbol will not have a significant effect on a large source ensemble. Witten et al. [1987] approximate the overhead due to the use of fixed precision at  $10^{-4}$  bits per source message, which is also negligible.

The arithmetic coding model for ensemble *EXAMPLE* is given in Figure 14. The final interval size is  $p(a)^2 \times p(b)^3 \times p(c)^4 \times p(d)^5 \times p(e)^6 \times p(f)^7 \times p(g)^8 \times p(space)^5$ . The number of bits needed to specify a value in the interval is  $-\log(1.44 \times 10^{-35}) = 115.7$ . So excluding overhead, arithmetic coding transmits *EXAMPLE* in 116 bits, one less bit than static Huffman coding.

Witten et al. [1987] provide an implementation of arithmetic coding, written in C, which separates the model of the source from the coding process (where the coding process is defined by eqs. (1) and (2)). The model is in a separate program module and is consulted by the encoder and the decoder at every step in the processing. The fact that the model can be separated so easily renders the classification static/adaptive irrelevant for this technique. Indeed, the fact that the coding method provides compression efficiency nearly equal to the entropy of the source under any model allows arithmetic coding to be coupled with

Source message	Probability	Cumulative probability	Range
<i>a</i>	.05	.05	[0, .05)
<i>b</i>	.075	.125	[.05, .125)
<i>c</i>	.1	.225	[.125, .225)
<i>d</i>	.125	.35	[.225, .35)
<i>e</i>	.15	.5	[.35, .5)
<i>f</i>	.175	.675	[.5, .675)
<i>g</i>	.2	.875	[.675, .875)
<i>space</i>	.125	1.0	[.875, 1.0)

**Figure 14.** The arithmetic coding model of *EXAMPLE*.

any static or adaptive method for computing the probabilities (or frequencies) of the source messages. Witten et al. [1987] implement an adaptive model similar to the techniques described in Section 4. The performance of this implementation is discussed in Section 6.

#### 4. ADAPTIVE HUFFMAN CODING

Adaptive Huffman coding was first conceived independently by Faller [1973] and Gallager [1978]. Knuth [1985] contributed improvements to the original algorithm, and the resulting algorithm is referred to as algorithm FGK. A more recent version of adaptive Huffman coding is described by Vitter [1987]. All of these methods are defined-word schemes that determine the mapping from source messages to code-words on the basis of a running estimate of the source message probabilities. The code is adaptive, changing so as to remain optimal for the current estimates. In this way, the adaptive Huffman codes respond to locality. In essence, the encoder is "learning" the characteristics of the source. The decoder must learn along with the encoder by continually updating the Huffman tree so as to stay in synchronization with the encoder.

Another advantage of these systems is that they require only one pass over the data. Of course, one-pass methods are not very interesting if the number of bits they transmit is significantly greater than that of the two-pass scheme. Interestingly, the performance of these methods, in terms of number of bits transmitted, can be better than that of static Huffman coding. This

does not contradict the optimality of the static method, since the static method is optimal only over all methods that assume a time-invariant mapping. The performance of the adaptive methods can also be worse than that of the static method. Upper bounds on the redundancy of these methods are presented in this section. As discussed in the Introduction, the adaptive method of Faller [1973], Gallager [1978], and Knuth [1985] is the basis for the UNIX utility *compact*. The performance of *compact* is quite good, providing typical compression factors of 30–40%.

#### 4.1 Algorithm FGK

The basis for algorithm FGK is the sibling property, defined by Gallager [1978]: A binary code tree has the sibling property if each node (except the root) has a sibling and if the nodes can be listed in order of nonincreasing weight with each node adjacent to its sibling. Gallager proves that a binary prefix code is a Huffman code if and only if the code tree has the sibling property. In algorithm FGK, both sender and receiver maintain dynamically changing Huffman code trees. The leaves of the code tree represent the source messages, and the weights of the leaves represent frequency counts for the messages. At any particular time,  $k$  of the  $n$  possible source messages have occurred in the message ensemble.

Initially, the code tree consists of a single leaf node, called the 0-node. The 0-node is a special node used to represent the  $n - k$  unused messages. For each message transmitted, both parties must increment the corresponding weight and recompute the code tree to maintain the sibling property. At the point in time when  $t$  messages have been transmitted,  $k$  of them distinct, and  $k < n$ , the tree is a legal Huffman code tree with  $k + 1$  leaves, one for each of the  $k$  messages and one for the 0-node. If the  $(t + 1)$ st message is one of the  $k$  already seen, the algorithm transmits  $a_{t+1}$ 's current code, increments the appropriate counter, and recomputes the tree. If an unused message occurs, the 0-node is split to create a pair of leaves, one for  $a_{t+1}$ , and a sibling

that is the new 0-node. Again, the tree is recomputed. In this case, the code for the 0-node is sent; in addition, the receiver must be told which of the  $n - k$  unused messages has appeared. In Figure 15, a simple example is given. At each node a count of occurrences of the corresponding message is stored. Nodes are numbered indicating their position in the sibling property ordering. The updating of the tree can be done in a single traversal from the  $a_{t+1}$  node to the root. This traversal must increment the count for the  $a_{t+1}$  node and for each of its ancestors. Nodes may be exchanged to maintain the sibling property, but all of these exchanges involve a node on the path from  $a_{t+1}$  to the root. Figure 16 shows the final code tree formed by this process on the ensemble *EXAMPLE*.

Disregarding overhead, the number of bits transmitted by algorithm FGK for the *EXAMPLE* is 129. The static Huffman algorithm would transmit 117 bits in processing the same data. The overhead associated with the adaptive method is actually less than that of the static algorithm. In the adaptive case the only overhead is the  $n \log n$  bits needed to represent each of the  $n$  different source messages when they appear for the first time. (This is in fact conservative; instead of transmitting a unique code for each of the  $n$  source messages, the sender could transmit the message's position in the list of remaining messages and save a few bits in the average case.) In the static case, the source messages need to be sent as does the shape of the code tree. As discussed in Section 3.2, an efficient representation of the tree shape requires  $2n$  bits. Algorithm FGK compares well with static Huffman coding on this ensemble when overhead is taken into account. Figure 17 illustrates an example on which algorithm FGK performs better than static Huffman coding even without taking overhead into account. Algorithm FGK transmits 47 bits for this ensemble, whereas the static Huffman code requires 53.

Vitter [1987] has proved that the total number of bits transmitted by algorithm FGK for a message ensemble of length  $t$  containing  $n$  distinct messages is bounded

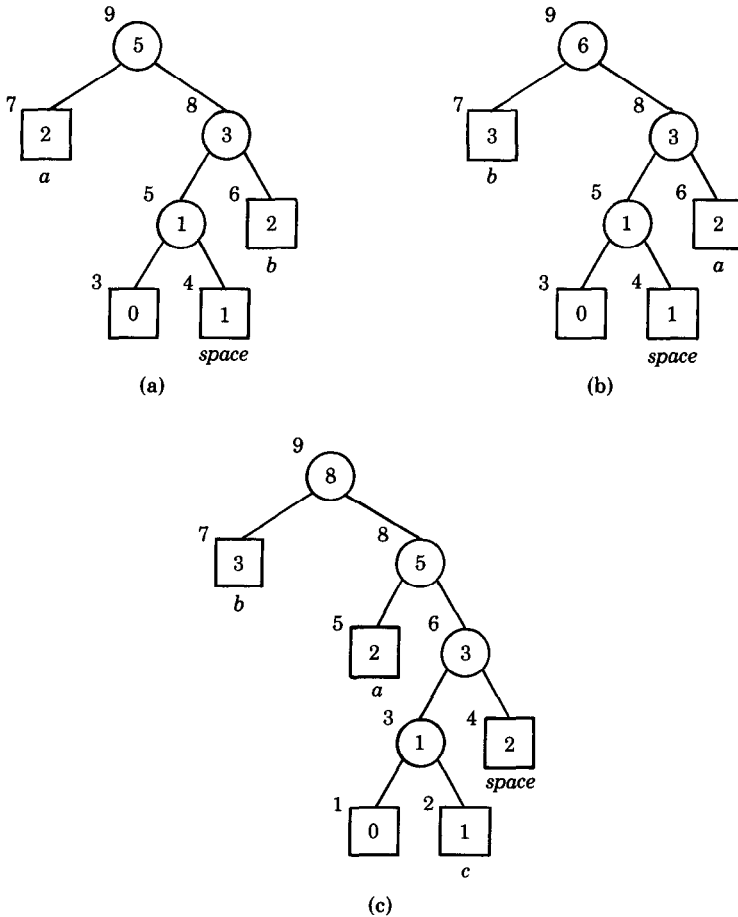

**Figure 15.** Algorithm FGK processing the ensemble *EXAMPLE*—(a) Tree after processing “aa bb”; 11 will be transmitted for the next *b*. (b) After encoding the third *b*; 101 will be transmitted for the next *space*; the form of the tree will not change—only the frequency counts will be updated; 100 will be transmitted for the first *c*. (c) Tree after update following first *c*.

below by  $S - n + 1$ , where  $S$  is the performance of the static method, and bounded above by  $2S + t - 4n + 2$ . So the performance of algorithm FGK is never much worse than twice optimal. Knuth [1985] provides a complete implementation of algorithm FGK and a proof that the time required for each encoding or decoding operation is  $O(l)$ , where  $l$  is the current length of the codeword. It should be noted that since the mapping is defined dynamically, (during transmission) the encoding and decoding algorithms stand alone; there is no additional algorithm to determine the mapping as in static methods.

#### 4.2 Algorithm V

The adaptive Huffman algorithm of Vitter (algorithm V) incorporates two improvements over algorithm FGK. First, the number of interchanges in which a node is moved upward in the tree during a recomputation is limited to one. This number is bounded in algorithm FGK only by  $l/2$ , where  $l$  is the length of the codeword for  $a_{t+1}$  when the recomputation begins. Second, Vitter’s method minimizes the values of  $\sum l_i$  and  $\max\{l_i\}$  subject to the requirement of minimizing  $\sum w_i l_i$ . The intuitive explanation of algorithm V’s advantage

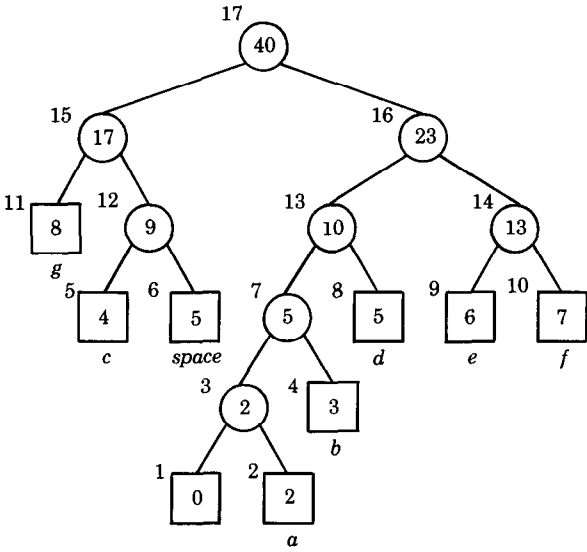

Figure 16. Tree formed by algorithm FGK for ensemble EXAMPLE.

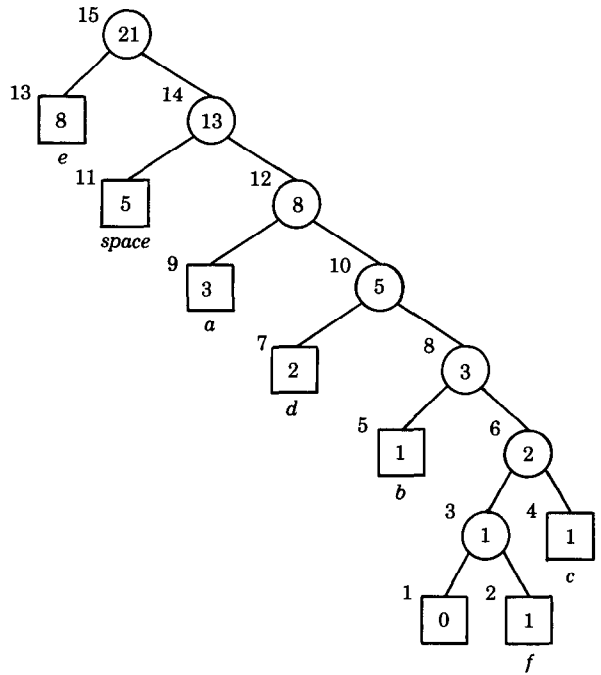

Figure 17. Tree formed by algorithm FGK for ensemble "e eae de eabe eae dcf".

over algorithm FGK is as follows: As in algorithm FGK, the code tree constructed by algorithm V is the Huffman code tree for the prefix of the ensemble seen so far. The adaptive methods do not assume that the relative frequencies of a prefix accu-

rately represent the symbol probabilities over the entire message. Therefore, the fact that algorithm V guarantees a tree of minimum height (height =  $\max\{l_i\}$ ) and minimum external path length ( $\sum l_i$ ) implies that it is better suited for coding the next

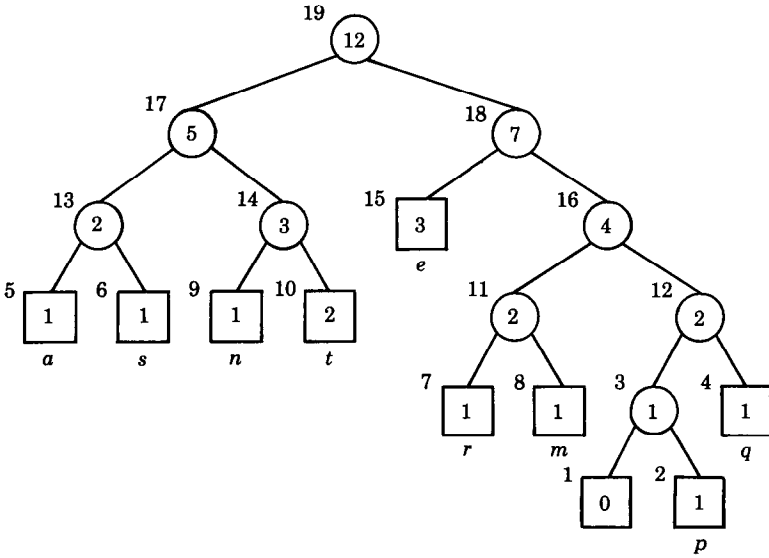

Figure 18. FGK tree with nonlevel order numbering.

message of the ensemble, given that any of the leaves of the tree may represent that next message.

These improvements are accomplished through the use of a new system for numbering nodes. The numbering, called an implicit numbering, corresponds to a level ordering of the nodes (from bottom to top and left to right). Figure 18 illustrates that the numbering of algorithm FGK is not always a level ordering. The following invariant is maintained in Vitter's algorithm: For each weight  $w$ , all leaves of weight  $w$  precede (in the implicit numbering) all internal nodes of weight  $w$ . Vitter [1987] proves that this invariant enforces the desired bound on node promotions. The invariant also implements bottom merging, as discussed in Section 3.2, to minimize  $\sum l_i$  and  $\max\{l_i\}$ . The difference between Vitter's method and algorithm FGK is in the way the tree is updated between transmissions. In order to understand the revised update operation, the following definition of a block of nodes is necessary: Blocks are equivalence classes of nodes defined by  $u \equiv v$  iff  $weight(u) = weight(v)$ , and  $u$  and  $v$  are either both leaves or both internal nodes. The leader of a block is the highest numbered (in the implicit numbering) node in the block. Blocks are ordered

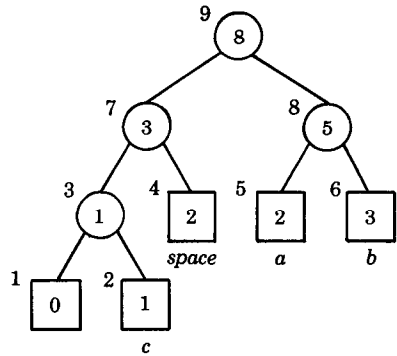

Figure 19. Algorithm V processing the ensemble "aa bbb c".

by increasing weight with the convention that a leaf block always precedes an internal block of the same weight. When an exchange of nodes is required to maintain the sibling property, algorithm V requires that the node being promoted be moved to the position currently occupied by the highest numbered node in the target block.

In Figure 19, the Vitter tree corresponding to Figure 15c is shown. This is the first point in *EXAMPLE* at which algorithm FGK and algorithm V differ significantly. At this point, the Vitter tree has height 3 and external path length 12,

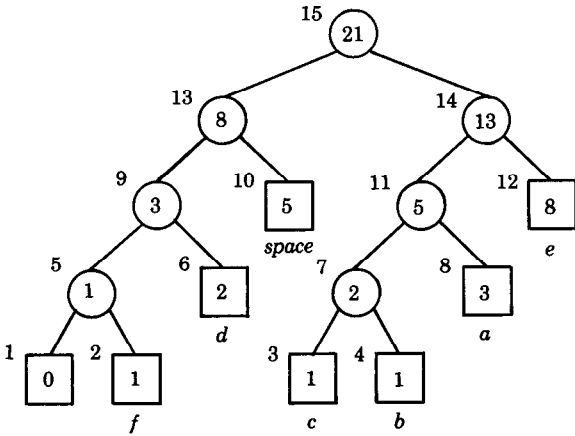

Figure 20. Tree formed by algorithm V for the ensemble of Figure 17.

whereas the FGK tree has height 4 and external path length 14. Algorithm V transmits codeword 001 for the second *c*; FGK transmits 1101. This demonstrates the intuition given earlier that algorithm V is better suited for coding the next message. The Vitter tree corresponding to Figure 16, representing the final tree produced in processing *EXAMPLE*, is only different from Figure 16 in that the internal node of weight 5 is to the right of both leaf nodes of weight 5. Algorithm V transmits 124 bits in processing *EXAMPLE*, as compared with the 129 bits of algorithm FGK and 117 bits of static Huffman coding. It should be noted that these figures do not include overhead and, as a result, disadvantage the adaptive methods.

Figure 20 illustrates the tree built by Vitter's method for the ensemble of Figure 17. Both  $\sum l_i$  and  $\max\{l_i\}$  are smaller in the tree of Figure 20. The number of bits transmitted during the processing of the sequence is 47, the same used by algorithm FGK. However, if the transmission continues with *d*, *b*, *c*, *f*, or an unused letter, the cost of algorithm V will be less than that of algorithm FGK. This again illustrates the benefit of minimizing the external path length ( $\sum l_i$ ) and the height ( $\max\{l_i\}$ ).

It should be noted again that the strategy of minimizing external path length and height is optimal under the assumption that any source letter is equally likely to occur next. Other reasonable strategies include one that assumes locality. To take advantage of locality, the ordering of tree

nodes with equal weights could be determined on the basis of recency. Another reasonable assumption about adaptive coding is that the weights in the current tree correspond closely to the probabilities associated with the source. This assumption becomes more reasonable as the length of the ensemble increases. Under this assumption, the expected cost of transmitting the next letter is  $\sum p_i l_i \approx \sum w_i l_i$ , so that neither algorithm FGK nor algorithm V has any advantage.

Vitter [1987] proves that the performance of his algorithm is bounded by  $S - n + 1$  from below and  $S + t - 2n + 1$  from above. At worst then, Vitter's adaptive method may transmit one more bit per codeword than the static Huffman method. The improvements made by Vitter do not change the complexity of the algorithm; algorithm V encodes and decodes in  $O(l)$  time, as does algorithm FGK.

### 5. OTHER ADAPTIVE METHODS

Two more adaptive data compression methods, algorithm BSTW and Lempel-Ziv coding, are discussed in this section. Like the adaptive Huffman coding techniques, these methods do not require a first pass to analyze the characteristics of the source. Thus they provide coding and transmission in real time. However, these schemes diverge from the fundamental Huffman coding approach to a greater degree than the methods discussed in Section 4. Algorithm BSTW is a defined-word

scheme that attempts to exploit locality. Lempel-Ziv coding is a *free-parse* method; that is, the words of the source alphabet are defined dynamically as the encoding is performed. Lempel-Ziv coding is the basis for the UNIX utility *compress*. Algorithm BSTW is a variable-variable scheme, whereas Lempel-Ziv coding is variable-block.

### 5.1 Lempel-Ziv Codes

Lempel-Ziv coding represents a departure from the classic view of a code as a mapping from a fixed set of source messages (letters, symbols, or words) to a fixed set of codewords. We coin the term *free-parse* to characterize this type of code, in which the set of source messages and the codewords to which they are mapped are defined as the algorithm executes. Whereas all adaptive methods create a set of codewords dynamically, defined-word schemes have a fixed set of source messages, defined by context (e.g., in text file processing the source messages might be single letters; in Pascal source file processing the source messages might be tokens). Lempel-Ziv coding defines the set of source messages as it parses the ensemble.

The Lempel-Ziv algorithm consists of a rule for parsing strings of symbols from a finite alphabet into substrings or words whose lengths do not exceed a prescribed integer  $L_1$  and a coding scheme that maps these substrings sequentially into uniquely decipherable codewords of fixed length  $L_2$  [Ziv and Lempel 1977]. The strings are selected so that they have very nearly equal probability of occurrence. As a result, frequently occurring symbols are grouped into longer strings, whereas infrequent symbols appear in short strings. This strategy is effective at exploiting redundancy due to symbol frequency, character repetition, and high-usage patterns. Figure 21 shows a small Lempel-Ziv code table. Low-frequency letters such as Z are assigned individually to fixed-length codewords (in this case, 12-bit binary numbers represented in base 10 for readability). Frequently occurring symbols, such as blank (represented by  $\backslash$ ) and zero, appear

Symbol string	Code
A	1
T	2
AN	3
TH	4
THE	5
AND	6
AD	7
$\backslash$	8
bb	9
bbb	10
0	11
00	12
000	13
0000	14
Z	15
###	4095

Figure 21. A Lempel-Ziv code table.

in long strings. Effective compression is achieved when a long string is replaced by a single 12-bit code.

The Lempel-Ziv method is an incremental parsing strategy in which the coding process is interlaced with a learning process for varying source characteristics [Ziv and Lempel 1977]. In Figure 21, run-length encoding of zeros and blanks is being learned.

The Lempel-Ziv algorithm parses the source ensemble into a collection of segments of gradually increasing length. At each encoding step, the longest prefix of the remaining source ensemble that matches an existing table entry ( $\alpha$ ) is parsed off, along with the character ( $c$ ) following this prefix in the ensemble. The new source message,  $\alpha c$ , is added to the code table. The new table entry is coded as  $(i, c)$ , where  $i$  is the codeword for the existing table entry and  $c$  is the appended character. For example, the ensemble 010100010 is parsed into  $\{0, 1, 01, 00, 010\}$  and is coded as  $\{(0, 0), (0, 1), (1, 1), (1, 0), (3, 0)\}$ . The table built for the message ensemble *EXAMPLE* is shown in Figure 22. The coded ensemble has the form  $\{(0, a), (1, \text{space}), (0, b), (3, b), (0, \text{space}), (0, c), (6, c), (6, \text{space}), (0, d), (9, d), (10, \text{space}), (0, e), (12, e), (13, e), (5, f), (0, f), (16, f), (17, f), (0, g), (19, g), (20, g), (20)\}$ . The string table is represented in a more efficient manner than in Figure 21;



Message	Codeword
<i>a</i>	1
<i>1space</i>	2
<i>b</i>	3
<i>3b</i>	4
<i>space</i>	5
<i>c</i>	6
<i>6c</i>	7
<i>6space</i>	8
<i>d</i>	9
<i>9d</i>	10
<i>10space</i>	11
<i>e</i>	12
<i>12e</i>	13
<i>13e</i>	14
<i>5f</i>	15
<i>f</i>	16
<i>16f</i>	17
<i>17f</i>	18
<i>g</i>	19
<i>19g</i>	20
<i>20g</i>	21

**Figure 22.** Lempel-Ziv table for the message ensemble *EXAMPLE* (code length = 173).

the string is represented by its prefix codeword followed by the extension character, so that the table entries have fixed length. The Lempel-Ziv strategy is simple, but greedy. It simply parses off the longest recognized string each time instead of searching for the best way to parse the ensemble.

The Lempel-Ziv method specifies fixed-length codewords. The size of the table and the maximum source message length are determined by the length of the codewords. It should be clear from the definition of the algorithm that Lempel-Ziv codes tend to be quite inefficient during the initial portion of the message ensemble. For example, even if we assume 3-bit codewords for characters *a-g* and *space* and 5-bit codewords for table indexes, the Lempel-Ziv algorithm transmits 173 bits for ensemble *EXAMPLE*. This compares poorly with the other methods discussed in this survey. The ensemble must be sufficiently long for the procedure to build up enough symbol frequency experience to achieve good compression over the full ensemble.

If the codeword length is not sufficiently large, Lempel-Ziv codes may also rise slowly to reasonable efficiency, maintain

good performance briefly, and fail to make any gains once the table is full and messages can no longer be added. If the ensemble's characteristics vary over time, the method may be "stuck with" the behavior it has learned and may be unable to continue to adapt.

Lempel-Ziv coding is asymptotically optimal, meaning that the redundancy approaches zero as the length of the source ensemble tends to infinity. However, for particular finite sequences, the compression achieved may be far from optimal [Storer and Szymanski 1982]. When the method begins, each source symbol is coded individually. In the case of 6- or 8-bit source symbols and 12-bit codewords, the method yields as much as 50% expansion during initial encoding. This initial inefficiency can be mitigated somewhat by initializing the string table to contain all of the source characters. Implementation issues are particularly important in Lempel-Ziv methods. A straightforward implementation takes  $O(n^2)$  time to process a string of  $n$  symbols; for each encoding operation, the existing table must be scanned for the longest message occurring as a prefix of the remaining ensemble. Rodeh et al. [1981] address the issue of computational complexity by defining a linear implementation of Lempel-Ziv coding based on suffix trees. The Rodeh et al. scheme is asymptotically optimal, but an input must be very long in order to allow efficient compression, and the memory requirements of the scheme are large,  $O(n)$  where  $n$  is the length of the source ensemble. It should also be mentioned that the method of Rodeh et al. constructs a variable-variable code; the pair  $(i, c)$  is coded using a representation of the integers, such as the Elias codes, for  $i$  and for  $c$  (a letter  $c$  can always be coded as the  $k$ th member of the source alphabet for some  $k$ ).

The other major implementation consideration involves the way in which the string table is stored and accessed. Welch [1984] suggests that the table be indexed by the codewords (integers  $1 \dots 2^L$ , where  $L$  is the maximum codeword length) and that the table entries be fixed-length, (codeword-extension) character pairs. Hashing is

proposed to assist in encoding. Decoding becomes a recursive operation in which the codeword yields the final character of the substring and another codeword. The decoder must continue to consult the table until the retrieved codeword is 0. Unfortunately, this strategy peels off extension characters in reverse order, and some type of stack operation must be used to reorder the source.

Storer and Szymanski [1982] present a general model for data compression that encompasses Lempel–Ziv coding. Their broad theoretical work compares classes of *macro schemes*, where macro schemes include all methods that factor out duplicate occurrences of data and replace them by references either to the source ensemble or to a code table. They also contribute a linear-time Lempel–Ziv-like algorithm with better performance than the standard Lempel–Ziv method.

Rissanen [1983] extends the Lempel–Ziv incremental parsing approach. Abandoning the requirement that the substrings partition the ensemble, the Rissanen method gathers “contexts” in which each symbol of the string occurs. The contexts are substrings of the previously encoded string (as in Lempel–Ziv), have varying size, and are in general overlapping. The Rissanen method hinges on the identification of a design parameter capturing the concept of “relevant” contexts. The problem of finding the best parameter is undecidable, and Rissanen suggests estimating the parameter experimentally.

As mentioned earlier, Lempel–Ziv coding is the basis for the UNIX utility *compress* and is one of the methods commonly used in file archival programs. The archival system PKARC uses Welch’s implementation, as does *compress*. The compression provided by *compress* is generally much better than that achieved by *compact* (the UNIX utility based on algorithm FGK) and takes less time to compute [UNIX 1984]. Typical compression values attained by *compress* are in the range of 50–60%.

## 5.2 Algorithm BSTW

The most recent of the algorithms surveyed here is due to Bentley, Sleator, Tarjan,

and Wei [1986]. This method, algorithm BSTW, possesses the advantage that it requires only one pass over the data to be transmitted and yet has performance that compares well to that of the static two-pass method along the dimension of number of bits per word transmitted. This number of bits is never much larger than the number of bits transmitted by static Huffman coding (in fact, it is usually quite close) and can be significantly better. Algorithm BSTW incorporates the additional benefit of taking advantage of locality of reference, the tendency for words to occur frequently for short periods of time and then fall into long periods of disuse. The algorithm uses a self-organizing list as an auxiliary data structure and shorter encodings for words near the front of this list. There are many strategies for maintaining self-organizing lists [Hester and Hirschberg 1985]; algorithm BSTW uses move to front.

A simple example serves to outline the method of algorithm BSTW. As in other adaptive schemes, sender and receiver maintain identical representations of the code, in this case message lists that are updated at each transmission using the move-to-front heuristic. These lists are initially empty. When message  $a_i$  is transmitted, if  $a_i$  is on the sender’s list, the sender transmits its current position. The sender then updates his or her list by moving  $a_i$  to position 1 and shifting each of the other messages down one position. The receiver similarly alters his or her word list. If  $a_i$  is being transmitted for the first time, then  $k + 1$  is the “position” transmitted, where  $k$  is the number of distinct messages transmitted so far. Some representation of the message itself must be transmitted as well, but just this first time. Again,  $a_i$  is moved to position 1 by both sender and receiver subsequent to its transmission. For the ensemble “*abcadeabfd*”, the transmission would be 1 *a* 2 *b* 3 *c* 3 4 *d* 5 *e* 3 5 6 *f* 5 (for ease of presentation, list positions are represented in base ten).

As the example shows, algorithm BSTW transmits each source message once; the rest of its transmission consists of encodings of list positions. Therefore, an essential feature of algorithm BSTW is a reasonable scheme for representation of

the integers. The methods discussed by Bentley et al. are the Elias codes presented in Section 3.3. The simple scheme, code  $\gamma$ , involves prefixing the binary representation of the integer  $i$  with  $\lfloor \log i \rfloor$  zeros. This yields a prefix code with the length of the codeword for  $i$  equal to  $2\lfloor \log i \rfloor + 1$ . Greater compression can be gained through use of the more sophisticated scheme  $\delta$ , which encodes an integer  $i$  in  $1 + \lfloor \log i \rfloor + 2\lfloor \log(1 + \lfloor \log i \rfloor) \rfloor$  bits.

A message ensemble on which algorithm BSTW is particularly efficient, described by Bentley et al., is formed by repeating each of  $n$  messages  $n$  times; for example,  $1^n 2^n 3^n \dots n^n$ . Disregarding overhead, a static Huffman code uses  $n^2 \log n$  bits (or  $\log n$  bits per message), whereas algorithm BSTW uses  $n^2 + 2 \sum_{i=1}^n \lfloor \log i \rfloor$  (which is less than or equal to  $n^2 + 2n \log n$  or  $O(1)$  bits per message). The overhead for algorithm BSTW consists of just the  $n \log n$  bits needed to transmit each source letter once. As discussed in Section 3.2, the overhead for static Huffman coding includes an additional  $2n$  bits. The locality present in ensemble *EXAMPLE* is similar to that in the above example. The transmission effected by algorithm BSTW is *1 a 1 2 space 3 b 1 1 2 4 c 1 1 1 2 5 d 1 1 1 1 2 6 e 1 1 1 1 2 7 f 1 1 1 1 1 1 8 g 1 1 1 1 1 1 1*. Using 3 bits for each source letter (*a-g* and *space*) and the Elias code  $\delta$  for list positions, the number of bits used is 81, which is a great improvement over all of the other methods discussed (only 69% of the length used by static Huffman coding). This could be improved further by the use of Fibonacci codes for list positions.

In Bentley et al. [1986] a proof is given that with the simple scheme for encoding integers, the performance of algorithm BSTW is bounded above by  $2S + 1$ , where  $S$  is the cost of the static Huffman coding scheme. Using the more sophisticated integer encoding scheme, the bound is  $1 + S + 2 \log(1 + S)$ . A key idea in the proofs given by Bentley et al. is the fact that, using the move-to-front heuristic, the integer transmitted for a message  $a_i$  will be one more than the number of different words transmitted since the last occurrence of  $a_i$ . Bentley et al. also prove that algorithm BSTW is asymptotically optimal.

An implementation of algorithm BSTW is described in great detail in Bentley et al. [1986]. In this implementation, encoding an integer consists of a table lookup; the codewords for the integers from 1 to  $n + 1$  are stored in an array indexed from 1 to  $n + 1$ . A binary trie is used to store the inverse mapping from codewords to integers. Decoding an Elias codeword to find the corresponding integer involves following a path in the trie. Two interlinked data structures, a binary trie and a binary tree, are used to maintain the word list. The trie is based on the binary encodings of the source words. Mapping a source message  $a_i$  to its list position  $p$  involves following a path in the trie, following a link to the tree, and then computing the symmetric order position of the tree node. Finding the source message  $a_i$  in position  $p$  is accomplished by finding the symmetric order position  $p$  in the tree and returning the word stored there. Using this implementation, the work done by sender and receiver is  $O(\text{length}(a_i) + \text{length}(w))$ , where  $a_i$  is the message being transmitted and  $w$  the codeword representing  $a_i$ 's position in the list. If the source alphabet consists of single characters, then the complexity of algorithm BSTW is just  $O(\text{length}(w))$ .

The "move-to-front" scheme of Bentley et al. was independently developed by Elias in his paper on *interval encoding* and *recency rank encoding* [Elias 1987]. Recency rank encoding is equivalent to algorithm BSTW. The name emphasizes the fact, mentioned above, that the codeword for a source message represents the number of distinct messages that have occurred since its most recent occurrence. Interval encoding represents a source message by the total number of messages that have occurred since its last occurrence (equivalently, the length of the interval since the last previous occurrence of the current message). It is obvious that the length of the interval since the last occurrence of a message  $a_i$  is at least as great as its recency rank, so that recency rank encoding never uses more, and generally uses fewer, symbols per message than interval encoding. The advantage to interval encoding is that it has a very simple implementation and can encode and decode selections from a very large alphabet

(a million letters, for example) at a micro-second rate [Elias 1987]. The use of interval encoding might be justified in a data transmission setting, where speed is the essential factor.

Ryabko [1987] also comments that the work of Bentley et al. coincides with many of the results in a paper in which he considers data compression by means of a "book stack" (the books represent the source messages, and as a "book" occurs it is taken from the stack and placed on top). Horspool and Cormack [1987] have considered "move-to-front," as well as several other list organization heuristics, in connection with data compression.

## 6. EMPIRICAL RESULTS

Empirical tests of the efficiencies of the algorithms presented here are reported in Bentley et al. [1986], Knuth [1985], Schwartz and Kallick [1964], Vitter [1987], and Welch [1984]. These experiments compare the number of bits per word required; processing time is not reported. Although theoretical considerations bound the performance of the various algorithms, experimental data are invaluable in providing additional insight. It is clear that the performance of each of these methods is dependent on the characteristics of the source ensemble.

Schwartz and Kallick [1964] test an implementation of static Huffman coding in which bottom merging is used to determine codeword lengths and all codewords of a given length are sequential binary numbers. The source alphabet in the experiment consists of 5114 frequently used English words, 27 geographical names, 10 numerals, 14 symbols, and 43 suffixes. The entropy of the document is 8.884 binary digits per message, and the average codeword constructed has length 8.920. The same document is also coded one character at a time. In this case the entropy of the source is 4.03, and the coded ensemble contains an average of 4.09 bits per letter. The redundancy is low in both cases. However, the *relative redundancy* (i.e., redundancy/entropy) is lower when the document is encoded by words.

Knuth [1985] describes algorithm FGK's performance on three types of data: a file containing the text of Grimm's first 10 fairy tales, text of a technical book, and a file of graphical data. For the first two files, the source messages are individual characters and the alphabet size is 128. The same data are coded using pairs of characters so that the alphabet size is 1968. For the graphical data, the number of source messages is 343. In the case of the fairy tales the performance of FGK is very close to optimum, although performance degrades with increasing file size. Performance on the technical book is not as good, but it is still respectable. The graphical data prove harder yet to compress, but again FGK performs reasonably well. In the latter two cases the trend of performance degradation with file size continues. Defining source messages to consist of character pairs results in slightly better compression, but the difference would not appear to justify the increased memory requirement imposed by the larger alphabet.

Vitter [1987] tests the performance of algorithms V and FGK against that of static Huffman coding. Each method is run on data that include Pascal source code, the  $\text{\TeX}$  source of the author's thesis, and electronic mail files. Figure 23 summarizes the results of the experiment for a small file of text. The performance of each algorithm is measured by the number of bits in the coded ensemble, and overhead costs are not included. Compression achieved by each algorithm is represented by the size of the file it creates, given as a percentage of the original file size. Figure 24 presents data for Pascal source code. For the  $\text{\TeX}$  source, the alphabet consists of 128 individual characters; for the other two file types, no more than 97 characters appear. For each experiment, when the overhead costs are taken into account, algorithm V outperforms static Huffman coding as long as the size of the message ensemble (number of characters) is no more than  $10^4$ . Algorithm FGK displays slightly higher costs, but never more than 100.4% of the static algorithm.

Witten et al. [1987] compare adaptive arithmetic coding with adaptive Huffman

$n$	$k$	Static	Algorithm V	Algorithm FGK
100	96	83.0	71.1	82.4
500	96	83.0	80.8	83.5
961	97	83.5	82.3	83.7

**Figure 23.** Simulation results for a small text file [Vitter 1987]:  $n$ , file size in 8-bit bytes;  $k$ , number of distinct messages.

$n$	$k$	Static	Algorithm V	Algorithm FGK
100	32	57.4	56.2	58.9
500	49	61.5	62.2	63.0
1000	57	61.3	61.8	62.4
10000	73	59.8	59.9	60.0
12067	78	59.6	59.8	59.9

**Figure 24.** Simulation results for Pascal source code [Vitter 1987]:  $n$ , file size in bytes;  $k$ , number of distinct messages.

coding. The version of arithmetic coding tested employs single-character adaptive frequencies and is a mildly optimized C implementation. Witten et al. compare the results provided by this version of arithmetic coding with the results achieved by the UNIX *compact* program (*compact* is based on algorithm FGK). On three large files that typify data compression applications, compression achieved by arithmetic coding is better than that provided by *compact*, but only slightly better (average file size is 98% of the *compact*ed size). A file over a three-character alphabet, with very skewed symbol probabilities, is encoded by arithmetic coding in less than 1 bit per character; the resulting file size is 74% of the size of the file generated by *compact*. Witten et al. also report encoding and decoding times. The encoding time of arithmetic coding is generally half the time required by the adaptive Huffman coding method. Decode time averages 65% of the time required by *compact*. Only in the case of the skewed file are the time statistics quite different. Arithmetic coding again achieves faster encoding, 67% of the time required by *compact*. However, *compact* decodes more quickly, using only 78% of the time of the arithmetic method.

Bentley et al. [1986] use C and Pascal source files, TROFF source files, and a terminal session transcript of several hours

for experiments that compare the performance of algorithm BSTW to static Huffman coding. Here the defined words consist of two disjoint classes, sequence of alphanumeric characters and sequences of non-alphanumeric characters. The performance of algorithm BSTW is very close to that of static Huffman coding in all cases. The experiments reported by Bentley et al. are of particular interest in that they incorporate another dimension, the possibility that in the move-to-front scheme one might want to limit the size of the data structure containing the codes to include only the  $m$  most recent words, for some  $m$ . The tests consider cache sizes of 8, 16, 32, 64, 128, and 256. Although performance tends to increase with cache size, the increase is erratic, with some documents exhibiting nonmonotonicity (performance that increases with cache size to a point and then decreases when cache size is further increased).

Welch [1984] reports simulation results for Lempel-Ziv codes in terms of compression ratios. His definition of compression ratio is the one given in Section 1.3,  $C = (\text{average message length})/(\text{average code-word length})$ . The ratios reported are 1.8 for English text, 2-6 for COBOL data files, 1.0 for floating-point arrays, 2.1 for formatted scientific data, 2.6 for system log data, 2.3 for source code, and 1.5 for object code. The tests involving English text files showed that long individual documents did not compress better than groups of short documents. This observation is somewhat surprising in that it seems to refute the intuition that redundancy is due at least in part to correlation in content. For purposes of comparison, Welch cites results of Pechura and Rubin. Pechura [1982] achieved a 1.5 compression ratio using static Huffman coding on files of English text. Rubin reports a 2.4 ratio for English text when using a complex technique for choosing the source messages to which Huffman coding is applied [Rubin 1976]. These results provide only a very weak basis for comparison, since the characteristics of the files used by the three authors are unknown. It is very likely that a single algorithm may produce compression ratios

ranging from 1.5 to 2.4, depending on the source to which it is applied.

## 7. SUSCEPTIBILITY TO ERROR

The discrete noiseless channel is, unfortunately, not a very realistic model of a communication system. Actual data transmission systems are prone to two types of error: *phase error*, in which a code symbol is lost or gained, and *amplitude error*, in which a code symbol is corrupted [Neumann 1962]. The degree to which channel errors degrade transmission is an important parameter in the choice of a data compression method. The susceptibility to error of a coding algorithm depends heavily on whether the method is static or adaptive.

### 7.1 Static Codes

It is generally known that Huffman codes tend to be self-correcting [Standish 1980]; that is, a transmission error tends not to propagate too far. The codeword in which the error occurs is incorrectly received, and it is likely that several subsequent codewords are misinterpreted, but before too long the receiver is back in synchronization with the sender. In a static code, synchronization means simply that both sender and receiver identify the beginnings of the codewords in the same way. In Figure 25 an example is used to illustrate the ability of a Huffman code to recover from phase errors. The message ensemble "BCDAEB" is encoded using the Huffman code of Figure 8 where the source letters  $a_1 \dots a_5$  represent A ... E, respectively, yielding the coded ensemble "0110100011000011". Figure 25 demonstrates the impact of loss of the first bit, the second bit, or the fourth bit. The dots show the way in which each line is parsed into codewords. The loss of the first bit results in resynchronization after the third bit so that only the first source message (B) is lost (replaced by AA). When the second bit is lost, the first eight bits of the coded ensemble are misinterpreted and synchronization is regained by bit 9. Dropping the fourth bit causes the same degree of disturbance as dropping the second.

The effect of amplitude errors is demonstrated in Figure 26. The format of the illustration is the same as that in Figure 25. This time bits 1, 2, and 4 are inverted rather than lost. Again synchronization is regained almost immediately. When bit 1 or bit 2 is changed, only the first three bits (the first character of the ensemble) are disturbed. Inversion of bit 4 causes loss of synchronization through the ninth bit. A very simple explanation of the self-synchronization present in these examples can be given. Since many of the codewords end in the same sequence of digits, the decoder is likely to reach a leaf of the Huffman code tree at one of the codeword boundaries of the original coded ensemble. When this happens, the decoder is back in synchronization with the encoder.

So that self-synchronization may be discussed more carefully, the following definitions are presented. (It should be noted that these definitions hold for arbitrary prefix codes so that the discussion includes all of the codes described in Section 3.) If  $s$  is a suffix of some codeword and there exist sequences of codewords  $\Gamma$  and  $\Delta$  such that  $s\Gamma = \Delta$ , then  $\Gamma$  is said to be a *synchronizing sequence* for  $s$ . For example, in the Huffman code used above, 1 is a synchronizing sequence for the suffix 01, whereas both 000001 and 011 are synchronizing sequences for the suffix 10. If every suffix (of every codeword) has a synchronizing sequence, then the code is *completely self-synchronizing*. If some or none of the proper suffixes have synchronizing sequences, then the code is, respectively, *partially* or *never self-synchronizing*. Finally, if there exists a sequence  $\Gamma$  that is a synchronizing sequence for every suffix,  $\Gamma$  is defined to be a *universal synchronizing sequence*. The code used in the examples above is completely self-synchronizing and has universal synchronizing sequence 00000011000. Gilbert and Moore [1959] prove that the existence of a universal synchronizing sequence is a necessary as well as a sufficient condition for a code to be completely self-synchronizing. They also state that any prefix code that is completely self-synchronizing will synchronize itself with

011.010.001.1.000.011.	Coded ensemble <i>BCDAEB</i>
1.1.010.001.1.000.011.	Bit 1 is lost, interpreted as <i>AACDAEB</i>
010.1.000.1.1.000.011.	Bit 2 is lost, interpreted as <i>CAEAAEB</i>
011.1.000.1.1.000.011.	Bit 4 is lost, interpreted as <i>BAEAAEB</i>

**Figure 25.** Recovery from phase errors.

0 1 1.0 1 0.00 1.1.000.011	Coded ensemble <i>BCDAEB</i>
1.1.1.0 1 0.00 1.1.000.011	Bit 1 is inverted, interpreted as <i>DCDAEB</i>
0 0 1.0 1 0.00 1.1.000.011	Bit 2 is inverted, interpreted as <i>AAACDAEB</i>
0 1 1.1.1.0 00.1.1.000.011	Bit 4 is inverted, interpreted as <i>BAAEAAEB</i>

**Figure 26.** Recovery from amplitude errors.

probability 1 if the source ensemble consists of successive messages independently chosen with any given set of probabilities. This is true since the probability of occurrence of the universal synchronizing sequence at any given time is positive.

It is important to realize that the fact that a completely self-synchronizing code will resynchronize with probability 1 does not guarantee recovery from error with bounded delay. In fact, for every completely self-synchronizing prefix code with more than two codewords, there are errors within one codeword that cause unbounded error propagation [Neumann 1962]. In addition, prefix codes are not always completely self-synchronizing. Bobrow and Hakimi [1969] state a necessary condition for a prefix code with codeword lengths  $l_1 \dots l_r$  to be completely self-synchronizing: the greatest common divisor of the  $l_i$  must be equal to 1. The Huffman code {00, 01, 10, 1100, 1101, 1110, 1111} is not completely self-synchronizing but is partially self-synchronizing since suffixes 00, 01, and 10 are synchronized by any codeword. The Huffman code {000, 0010, 0011, 01, 100, 1010, 1011, 100, 111} is never self-synchronizing. Examples of never self-synchronizing Huffman codes are difficult to construct, and the example above is the only one with fewer than 16 source messages. Stiffler [1971] proves that a code is never self-synchronizing if and only if none of the proper suffixes of the codewords are themselves codewords.

The conclusions that may be drawn from the above discussion are as follows: Although it is common for Huffman codes to

self-synchronize, this is not guaranteed, and when self-synchronization is assured, there is no bound on the propagation of the error. An additional difficulty is that self-synchronization provides no indication that an error has occurred.

The problem of error detection and correction in connection with Huffman codes has not received a great deal of attention. Several ideas on the subject are reported here. Rudner [1971] states that synchronizing sequences should be as short as possible to minimize resynchronization delay. In addition, if a synchronizing sequence is used as the codeword for a high probability message, then resynchronization will be more frequent. A method for constructing a minimum-redundancy code having the shortest possible synchronizing sequence is described by Rudner [1971]. Neumann [1962] suggests purposely adding some redundancy to Huffman codes in order to permit detection of certain types of errors. Clearly this has to be done carefully so as not to negate the redundancy reduction provided by Huffman coding. McIntyre and Pechura [1985] cite data integrity as an advantage of the codebook approach discussed in Section 3.2. When the code is stored separately from the coded data, the code may be backed up to protect it from perturbation. However, when the code is stored or transmitted with the data, it is susceptible to errors. An error in the code representation constitutes a drastic loss, and therefore extreme measures for protecting this part of the transmission are justified.

The Elias codes of Section 3.3 are not at all robust. Each of the codes  $\gamma$  and  $\delta$  can be

001 1 0.00 1 00.0 00100 0.	Coded integers 6, 4, 8
0 1 1.0 00 1 00 0.00100.0	Bit 2 is lost, interpreted as 3, 8, 2, etc.
011.1.0 00 1 00 0.00100.0	Bit 2 is inverted, interpreted as 3, 1, 8, 4, etc.
000 1 0 00.1.00 0 00100 0	Bit 3 is inverted, interpreted as 8, 1, etc.

**Figure 27.** Effects of errors in Elias codes.

000011.000011.00011.010 11.01011.	Coded ensemble "aa bb"
00 011.000011.00011.010 11.01011.	Bit 3 is lost, interpreted as "a bb"
001011.000011.00011.010 11.01011.	Bit 3 is inverted, interpreted as "?a bb"
00001 000011.00011.010 11.01011.	Bit 6 is lost, interpreted as "? bb"
000010 000011.00011.010 11.01011.	Bit 6 is inverted, interpreted as "? bb"
000011.000011.00011.011.11.01011.	Bit 20 is inverted, interpreted as "aa fgb"

**Figure 28.** Effects of errors in Fibonacci codes.

thought of as generating codewords that consist of a number of substrings such that each substring encodes the length of the subsequent substring. For code  $\gamma$  we may think of each codeword  $\gamma(x)$  as the concatenation of  $z$ , a string of  $n$  zeros, and  $b$ , a string of length  $n + 1$  ( $n = \lfloor \log x \rfloor$ ). If one of the zeros in substring  $z$  is lost, synchronization will be lost since the last symbol of  $b$  will be pushed into the next codeword.

Since the 1 at the front of substring  $b$  delimits the end of  $z$ , if a zero in  $z$  is changed to a 1, synchronization will be lost as symbols from  $b$  are pushed into the following codeword. Similarly, if ones at the front of  $b$  are inverted to zeros, synchronization will be lost since the codeword  $\gamma(x)$  consumes symbols from the following codeword. Once synchronization is lost, it cannot normally be recovered.

In Figure 27, codewords  $\gamma(6)$ ,  $\gamma(4)$ ,  $\gamma(8)$  are used to illustrate the above ideas. In each case, synchronization is lost and never recovered.

The Elias code  $\delta$  may be thought of as a three-part ramp, where  $\delta(x) = zmb$  with  $z$  a string of  $n$  zeros,  $m$  a string of length  $n + 1$  with binary value  $v$ , and  $b$  a string of length  $v - 1$ . For example, in  $\delta(16) = 00.101.0000$ ,  $n = 2$ ,  $v = 5$ , and the final substring is the binary value of 16 with the leading 1 removed so that it has length  $v - 1 = 4$ . Again the fact that each substring determines the length of the subsequent substring means that an error in one of the

first two substrings is disastrous, changing the way in which the rest of the codeword is to be interpreted. And, like code  $\gamma$ , code  $\delta$  has no properties that aid in regaining synchronization once it has been lost.

The Fibonacci codes of Section 3.3, on the other hand, are quite robust. This robustness is due to the fact that every codeword ends in the substring 11 and that substring can appear nowhere else in a codeword. If an error occurs anywhere other than in the 11 substring, the error is contained within that one codeword. It is possible that one codeword will become two (see the sixth line of Figure 28), but no other codewords will be distributed. If the last symbol of a codeword is lost or changed, the current codeword will be fused with its successor so that two codewords are lost. When the penultimate bit is disturbed, up to three codewords can be lost. For example the coded message 011.11.011 becomes 0011.1011 if bit 2 is inverted. The maximum disturbance resulting from either an amplitude error or a phase error is the disturbance of three codewords.

In Figure 28, some illustrations based on the Fibonacci coding of ensemble *EXAMPLE* as shown in Figure 12 are given. When bit 3 (which is not part of an 11 substring) is lost or changed, only a single codeword is degraded. When bit 6 (the final bit of the first codeword) is lost or changed, the first two codewords are incorrectly decoded. When bit 20 is changed, the first  $b$  is incorrectly decoded as *fgb*.



## 7.2 Adaptive Codes

Adaptive codes are far more adversely affected by transmission errors than static codes. For example, in the case of an adaptive Huffman code, even though the receiver may resynchronize with the sender in terms of correctly locating the beginning of a codeword, the information lost represents more than a few bits or a few characters of the source ensemble. The fact that sender and receiver are dynamically redefining the code indicates that by the time synchronization is regained, they may have radically different representations of the code. Synchronization as defined in Section 7.1 refers to synchronization of the bit stream, which is not sufficient for adaptive methods. What is needed here is *code synchronization*, that is, synchronization of both the bit stream and the dynamic data structure representing the current code mapping.

There is no evidence that adaptive methods are self-synchronizing. Bentley et al. [1986] note that, in algorithm BSTW, loss of synchronization can be catastrophic, whereas this is not true with static Huffman coding. Ziv and Lempel [1977] recognize that the major drawback of their algorithm is its susceptibility to error propagation. Welch [1984] also considers the problem of error tolerance of Lempel-Ziv codes and suggests that the entire ensemble be embedded in an error-detecting code. Neither static nor adaptive arithmetic coding has the ability to tolerate errors.

## 8. NEW DIRECTIONS

Data compression is still very much an active research area. This section suggests possibilities for further study.

The discussion of Section 7 illustrates the susceptibility to error of the codes presented in this survey. Strategies for increasing the reliability of these codes while incurring only a moderate loss of efficiency would be of great value. This area appears to be largely unexplored. Possible approaches include embedding the entire ensemble in an error-correcting code or reserving one or more codewords to act as

error flags. For adaptive methods it may be necessary for receiver and sender to verify the current code mapping periodically.

For adaptive Huffman coding, Gallager [1978] suggests an "aging" scheme, whereby recent occurrences of a character contribute more to its frequency count than do earlier occurrences. This strategy introduces the notion of locality into the adaptive Huffman scheme. Cormack and Horspool [1984] describe an algorithm for approximating exponential aging. However, the effectiveness of this algorithm has not been established.

Both Knuth [1985] and Bentley et al. [1986] suggest the possibility of using the "cache" concept to exploit locality and minimize the effect of anomalous source messages. Preliminary empirical results indicate that this may be helpful. A problem related to the use of a cache is overhead time required for deletion. Strategies for reducing the cost of a deletion could be considered. Another possible extension to algorithm BSTW is to investigate other locality heuristics. Bentley et al. [1986] prove that intermittent move-to-front (move-to-front after every  $k$  occurrences) is as effective as move-to-front. It should be noted that there are many other self-organizing methods yet to be considered. Horspool and Cormack [1987] describe experimental results that imply that the transpose heuristic performs as well as move-to-front and suggest that it is also easier to implement.

Several aspects of free-parse methods merit further attention. Lempel-Ziv codes appear to be promising, although the absence of a worst-case bound on the redundancy of an individual finite source ensemble is a drawback. The variable-block type Lempel-Ziv codes have been implemented with some success [ARC 1986], and the construction of a variable-variable Lempel-Ziv code has been sketched [Ziv and Lempel 1978]. The efficiency of the variable-variable model should be investigated. In addition, an implementation of Lempel-Ziv coding that combines the time efficiency of the Rodeh et al. [1981] method with more efficient use of space is worthy of consideration.

Another important research topic is the development of theoretical models for data compression that address the problem of local redundancy. Models based on Markov chains can be exploited to take advantage of interaction between groups of symbols. Entropy tends to be overestimated when symbol interaction is not considered. Models that exploit relationships between source messages may achieve better compression than predicted by an entropy calculation based only on symbol probabilities. The use of Markov modeling is considered by Llewellyn [1987] and by Langdon and Rissanen [1983].

## 9. SUMMARY

Data compression is a topic of much importance and many applications. Methods of data compression have been studied for almost four decades. This paper has provided an overview of data compression methods of general utility. The algorithms have been evaluated in terms of the amount of compression they provide, algorithm efficiency, and susceptibility to error. Although algorithm efficiency and susceptibility to error are relatively independent of the characteristics of the source ensemble, the amount of compression achieved depends on the characteristics of the source to a great extent.

Semantic dependent data compression techniques, as discussed in Section 2, are special-purpose methods designed to exploit local redundancy or context information. A semantic dependent scheme can usually be viewed as a special case of one or more general-purpose algorithms. It should also be noted that algorithm BSTW is a general-purpose technique that exploits locality of reference, a type of local redundancy.

Susceptibility to error is the main drawback of each of the algorithms presented here. Although channel errors are more devastating to adaptive algorithms than to static ones, it is possible for an error to propagate without limit even in the static case. Methods of limiting the effect of an error on the effectiveness of a

data compression algorithm should be investigated.

## REFERENCES

- ABRAMSON, N. 1963. *Information Theory and Coding*. McGraw-Hill, New York.
- APOSTOLICO, A., AND FRAENKEL, A. S. 1985. Robust transmission of unbounded strings using Fibonacci representations. Tech. Rep. CS85-14, Dept. of Applied Mathematics, The Weizmann Institute of Science, Rehovot, Israel.
- ARC 1986. *ARC File Archive Utility*, Version 5.1. System Enhancement Associates, Wayne, N.J.
- ASH, R. B. 1965. *Information Theory*. Interscience, New York.
- BENTLEY, J. L., SLEATOR, D. D., TARJAN, R. E., AND WEI, V. K. 1986. A locally adaptive data compression scheme. *Commun. ACM* 29, 4 (Apr.), 320-330.
- BOBROW, L. S., AND HAKIMI, S. L. 1969. Graph theoretic prefix codes and their synchronizing properties. *Inf. Contr.* 15, 1 (July), 70-94.
- BRENT, R. P., AND KUNG, H. T. 1978. Fast algorithms for manipulating formal power series. *J. ACM* 25, 4 (Oct.), 581-595.
- CAPOCELLI, R. M., GIANCARLO, R., AND TANEJA, I. J. 1986. Bounds on the redundancy of Huffman codes. *IEEE Trans. Inf. Theory* 32, 6 (Nov.), 854-857.
- CAPPELLINI, V., ED. 1985. *Data Compression and Error Control Techniques with Applications*. Academic Press, London.
- CONNELL, J. B. 1973. A Huffman-Shannon-Fano code. *Proc. IEEE* 61, 7 (July), 1046-1047.
- CORMACK, G. V. 1985. Data compression on a database system. *Commun. ACM* 28, 12 (Dec.), 1336-1342.
- CORMACK, G. V., AND HORSPOOL, R. N. 1984. Algorithms for adaptive Huffman codes. *Inf. Process. Lett.* 18, 3 (Mar.), 159-165.
- CORTESI, D. 1982. An effective text-compression algorithm. *BYTE* 7, 1 (Jan.), 397-403.
- COT, N. 1977. Characterization and design of optimal prefix codes. Ph.D. dissertation, Computer Science Dept., Stanford Univ., Stanford, Calif.
- ELIAS, P. 1975. Universal codeword sets and representations of the integers. *IEEE Trans. Inf. Theory* 21, 2 (Mar.), 194-203.
- ELIAS, P. 1987. Interval and recency rank source coding: Two on-line adaptive variable-length schemes. *IEEE Trans. Inf. Theory* 33, 1 (Jan.), 3-10.
- FALLER, N. 1973. An adaptive system for data compression. In *Record of the 7th Asilomar Conference on Circuits, Systems and Computers* (Pacific Grove, Calif., Nov.). Naval Postgraduate School, Monterey, Calif., pp. 593-597.
- FANO, R. M. 1949. *Transmission of Information*. M.I.T. Press, Cambridge, Mass.

- FRAENKEL, A. S., AND KLEIN, S. T. 1985. Robust universal complete codes as alternatives to Huffman codes. Tech. Rep. CS85-16, Dept. of Applied Mathematics, The Weizmann Institute of Science, Rehovot, Israel.
- FRAENKEL, A. S., MOR, M., AND PERL, Y. 1983. Is text compression by prefixes and suffixes practical? *Acta Inf.* 20, 4 (Dec.), 371-375.
- GALLAGER, R. G. 1968. *Information Theory and Reliable Communication*. Wiley, New York.
- GALLAGER, R. G. 1978. Variations on a theme by Huffman. *IEEE Trans. Inf. Theory* 24, 6 (Nov.), 668-674.
- GAREY, M. R. 1974. Optimal binary search trees with restricted maximal depth. *SIAM J. Comput.* 3, 2 (June), 101-110.
- GILBERT, E. N. 1971. Codes based on inaccurate source probabilities. *IEEE Trans. Inf. Theory* 17, 3 (May), 304-314.
- GILBERT, E. N., AND MOORE, E. F. 1959. Variable-length binary encodings. *Bell Syst. Tech. J.* 38, 4 (July), 933-967.
- GLASSEY, C. R., AND KARP, R. M. 1976. On the optimality of Huffman trees. *SIAM J. Appl. Math.* 31, 2 (Sept.), 368-378.
- GONZALEZ, R. C., AND WINTZ, P. 1977. *Digital Image Processing*. Addison-Wesley, Reading, Mass.
- HAHN, B. 1974. A new technique for compression and storage of data. *Commun. ACM* 17, 8 (Aug.), 434-436.
- HESTER, J. H., AND HIRSCHBERG, D. S. 1985. Self-organizing linear search. *ACM Comput. Surv.* 17, 3 (Sept.), 295-311.
- HORSPOOL, R. N., AND CORMACK, G. V. 1987. A locally adaptive data compression scheme. *Commun. ACM* 30, 9 (Sept.), 792-794.
- HU, T. C., AND TAN, K. C. 1972. Path length of binary search trees. *SIAM J. Appl. Math.* 22, 2 (Mar.), 225-234.
- HU, T. C., AND TUCKER, A. C. 1971. Optimal computer search trees and variable-length alphabetic codes. *SIAM J. Appl. Math.* 21, 4 (Dec.), 514-532.
- HUFFMAN, D. A. 1952. A method for the construction of minimum-redundancy codes. *Proc. IRE* 40, 9 (Sept.), 1098-1101.
- INGELS, F. M. 1971. *Information and Coding Theory*. Intext, Scranton, Penn.
- ITAI, A. 1976. Optimal alphabetic trees. *SIAM J. Comput.* 5, 1 (Mar.), 9-18.
- KARP, R. M. 1961. Minimum redundancy coding for the discrete noiseless channel. *IRE Trans. Inf. Theory* 7, 1 (Jan.), 27-38.
- KNUTH, D. E. 1971. Optimum binary search trees. *Acta Inf.* 1, 1 (Jan.), 14-25.
- KNUTH, D. E. 1985. Dynamic Huffman coding. *J. Algorithms* 6, 2 (June), 163-180.
- KRAUSE, R. M. 1962. Channels which transmit letters of unequal duration. *Inf. Control* 5, 1 (Mar.), 13-24.
- LAESER, R. P., MCLAUGHLIN, W. I., AND WOLFF, D. M. 1986. Engineering Voyager 2's encounter with Uranus. *Sci. Am.* 255, 5 (Nov.), 36-45.
- LANGDON, G. G., AND RISSANEN, J. J. 1983. A double-adaptive file compression algorithm. *IEEE Trans. Comm.* 31, 11 (Nov.), 1253-1255.
- LLEWELLYN, J. A. 1987. Data compression for a source with Markov characteristics. *Comput. J.* 30, 2, 149-156.
- MCINTYRE, D. R., AND PECHURA, M. A. 1985. Data compression using static Huffman code-decode tables. *Commun. ACM* 28, 6 (June), 612-616.
- MEHLHORN, K. 1980. An efficient algorithm for constructing nearly optimal prefix codes. *IEEE Trans. Inf. Theory* 26, 5 (Sept.), 513-517.
- NEUMANN, P. G. 1962. Efficient error-limiting variable-length codes. *IRE Trans. Inf. Theory* 8, 4 (July), 292-304.
- PARKER, D. S. 1980. Conditions for the optimality of the Huffman algorithm. *SIAM J. Comput.* 9, 3 (Aug.), 470-489.
- PASCO, R. 1976. Source coding algorithms for fast data compression. Ph.D. dissertation, Dept. of Electrical Engineering, Stanford Univ., Stanford, Calif.
- PECHURA, M. 1982. File archival techniques using data compression. *Commun. ACM* 25, 9 (Sept.), 605-609.
- PERL, Y., GAREY, M. R., AND EVEN, S. 1975. Efficient generation of optimal prefix code: Equiprobable words using unequal cost letters. *J. ACM* 22, 2 (Apr.), 202-214.
- PKARC FAST! 1987. *PKARC FAST! File Archival Utility*, Version 3.5. PKWARE, Inc. Glendale, Wis.
- REGHBATI, H. K. 1981. An overview of data compression techniques. *Computer* 14, 4 (Apr.), 71-75.
- RISSANEN, J. J. 1976. Generalized Kraft inequality and arithmetic coding. *IBM J. Res. Dev.* 20 (May), 198-203.
- RISSANEN, J. J. 1983. A universal data compression system. *IEEE Trans. Inf. Theory* 29, 5 (Sept.), 656-664.
- RODEH, M., PRATT, V. R., AND EVEN, S. 1981. Linear algorithm for data compression via string matching. *J. ACM* 28, 1 (Jan.), 16-24.
- RUBIN, F. 1976. Experiments in text file compression. *Commun. ACM* 19, 11 (Nov.), 617-623.
- RUBIN, F. 1979. Arithmetic stream coding using fixed precision registers. *IEEE Trans. Inf. Theory* 25, 6 (Nov.), 672-675.
- RUDNER, B. 1971. Construction of minimum-redundancy codes with optimal synchronizing property. *IEEE Trans. Inf. Theory* 17, 4 (July), 478-487.
- RUTH, S. S., AND KREUTZER, P. J. 1972. Data compression for large business files. *Datamation* 18, 9 (Sept.), 62-66.

- RYABKO, B. Y. 1987. A locally adaptive data compression scheme. *Commun. ACM* 16, 2 (Sept.), 792.
- SAMET, H. 1984. The Quadtree and related hierarchical data structures. *ACM Comput. Surv.* 30, 9 (June), 187-260.
- SCHWARTZ, E. S. 1964. An optimum encoding with minimum longest code and total number of digits. *Inf. Control* 7, 1 (Mar.), 37-44.
- SCHWARTZ, E. S., AND KALLICK, B. 1964. Generating a canonical prefix encoding. *Commun. ACM* 7, 3 (Mar.), 166-169.
- SEVERANCE, D. G. 1983. A practitioner's guide to data base compression. *Inf. Syst.* 8, 1, 51-62.
- SHANNON, C. E., AND WEAVER, W. 1949. *The Mathematical Theory of Communication*. University of Illinois Press, Urbana, Ill.
- SNYDERMAN, M., AND HUNT, B. 1970. The myriad virtues of text compaction. *Datamation* 16, 12 (Dec.), 36-40.
- STANDISH, T. A. 1980. *Data Structure Techniques*. Addison-Wesley, Reading, Mass.
- STIFFLER, J. J. 1971. *Theory of Synchronous Communications*. Prentice-Hall, Englewood Cliffs, N.J.
- STORER, J. A., AND SZYMANSKI, T. G. 1982. Data compression via textual substitution. *J. ACM* 29, 4 (Oct.), 928-951.
- TANAKA, H. 1987. Data structure of Huffman codes and its application to efficient encoding and decoding. *IEEE Trans. Inf. Theory* 33, 1 (Jan.), 154-156.
- TROPPER, R. 1982. Binary-coded text, A text-compression method. *BYTE* 7, 4 (Apr.), 398-413.
- UNIX. 1984. *UNIX User's Manual*, Version 4.2. Berkeley Software Distribution, Virtual VAX-11 Version, Univ. of California, Berkeley, Calif.
- VARN, B. 1971. Optimal variable length codes (arbitrary symbol cost and equal code word probability). *Inf. Control* 19, 4 (Nov.), 289-301.
- VITTER, J. S. 1987. Design and analysis of dynamic Huffman codes. *J. ACM* 34, 4 (Oct.), 825-845.
- WAGNER, R. A. 1973. Common phrases and minimum-space text storage. *Commun. ACM* 16, 3 (Mar.), 148-152.
- WELCH, T. A. 1984. A technique for high-performance data compression. *Computer* 17, 6 (June), 8-19.
- WILKINS, L. C., AND WINTZ, P. A. 1971. Bibliography on data compression, picture properties and picture coding. *IEEE Trans. Inf. Theory* 17, 2, 180-197.
- WITTEN, I. H., NEAL, R. M., AND CLEARY, J. G. 1987. Arithmetic coding for data compression. *Commun. ACM* 30, 6 (June), 520-540.
- ZIMMERMAN, S. 1959. An optimal search procedure. *Am. Math. Monthly* 66, (Oct.), 690-693.
- ZIV, J., AND LEMPEL, A. 1977. A universal algorithm for sequential data compression. *IEEE Trans. Inf. Theory* 23, 3 (May), 337-343.
- ZIV, J., AND LEMPEL, A. 1978. Compression of individual sequences via variable-rate coding. *IEEE Trans. Inf. Theory* 24, 5 (Sept.), 530-536.

Received May 1987; final revision accepted January 1988.